

DOPPLER FETUS DETECTOR

FD-490(FD-491/FD-492)

Operation Manual



CAUTION

- This device can only be operated by a physician or under the direction of a physician.
- Read this instruction manual carefully before use and operate the device according to the instructions in the manual.
- Keep this operation manual close by for reference in the event of any questions regarding use. Inappropriate handling may result in an accident.

CE
1639

Importer



Medexa Diagnostisk service AB

11b Krossverksgatan Limhamn Sweden

Tel: +46040160020

E-mail: info@medexa.se

URL: <https://www.medexa.se/>

Authorized Representative in Europe



Emergo Europe

Westervoortsedijk 60

6827 AT Arnhem

The Netherlands

Tel: (31) (0) 70 345 8570

Fax: (31) (0) 70 346 7299

INTRODUCTION

Thank you for purchasing the Doppler Fetus Detector FD-490. Please read this operation manual to ensure safe, proper use of this device. This device was inspected for confirmation of problem-free operation before factory shipment. After opening the package, please check for damage during transport and read this operation manual carefully to ensure proper operation. In the event of any damage or problems with the operation of this device, Please contact us or distributor.

- This operation manual
 - Describes of the handling necessary to use the Doppler Fetus Detector FD-490 and the safety precautions must be followed. Read this operation manual carefully before use to ensure safe, proper operation. Any deviation from the instructions in this manual may result in poor performance or damage to the device. All users must read “For Safe, Proper Use” even when familiar with the handling of this device. Carelessness may result in a serious accident.
- The intended use of this device is as follows:
 - The Doppler Fetus Detector FD-490 will detect fetal heart sounds, sounds of umbilical blood flow, or the fetal position based on Doppler signals from the fetal heart, umbilical blood flow, and other sounds from the early stage of pregnancy to parturition.
- To use this device in the proper condition:
 - Proper operation and periodic maintenance is required. Only qualified personnel should repair this device. Toitu (hereinafter the “Company”) and agents of the Company will assume no responsibility for the performance of this device and the safety of users for improper use or repair by unqualified personnel.

For Safe and Proper Use

In this operation manual, precautions to observe are classified as “Warning” and “Caution” and described with pictograms. These signs are classified as follows according to the hazard level. Read the body text and fully understand the meaning.



Failure to heed this precaution may result in death or serious injury.



Failure to heed this precaution may result in personal injury or damage to property.

List of Warnings

The following are all of the warnings. They may be described in the body text as needed. Read carefully for safe, proper use.

To prevent the possibility of death or injury, breakdown, and incorrect operation

1. Follow the instructions in this operation manual. In the event of an abnormality, stop operation immediately.
2. Be sure to check the device before use. If you cannot confirm proper operation by inspection, turn off the power and remove the power plug from the outlet. Stop using the device, attach a label stating "Breakdown", and ask our office or distributor for immediate repairs. [Failure to follow these instructions may result in an accident, false recognition, or device malfunction.]
3. Do not disassemble or modify this device. [Failure to follow these instructions may result in an accident or device malfunction.]

For the wireless type;

4. If two or more of these devices are used in the same facility, check the pairing of the main unit and the wireless. Failure to follow these instructions may result in a mix-up of patients.
5. If there is a wireless device other than this device that may cause interference, consult us or distributor about measures to prevent such interference (e.g. installation of partitions).

To prevent misdiagnosis

1. Do not use a probe that does not emit a Doppler sound.
2. Adjust the probe to the optimum position in response to fetal movement. If the probe contacts a maternal blood vessel, the device will detect the maternal heart rate.
3. If intrauterine fetal death is suspected by this examination, examine using another method.

To prevent electric shock

1. Be sure to use the provided power cord.
The use of other power cords may cause electric shock to the patient and the user.
2. Attach or remove the battery after unplugging the power cord.
Do not operate devices when wet or with wet hands. Doing so may cause a breakdown of the device or electric shock to the user.

To prevent infection

1. Clean and disinfect this device after every use.
2. This device is not disinfected before shipment. Be sure to disinfect and clean before use.

To prevent explosion and fire

1. Do not use in a location where there is a risk of explosion, such as environment with flammable anesthetic gas or oxygen.
2. Do not place heavy objects on the power cord or expose the power cord to the weight of other objects. Do not damage, abuse, twist, pull, or heat the cord. In the event of damage to the power cord (exposed core or breakage), ask our office or distributor for an exchange.

To avoid electromagnetic effects

1. This device may cause poor transmission or interfere with other devices because of radio interference. Such interference requires changing the direction or installation location of this device or measures to reduce interference such as a shield.
2. Use of accessories, probes, and cables other than the specified ones may cause an increase in emissions or reduce the resistance to interference of this device.
3. If this device is used close to or stacked on top of another device, check the correct operation in the arrangement used.
4. Use a cable of 1.2 m or less in length for the earphones.
5. Attach a connector cover to a connector that is not in use. (Connector for Wired probe)
6. Pins of connectors identified with ESD warning symbol should not be touched and that connections should not be made to these connectors unless ESD precautionary procedures are used. We recommend that all staff involved receive an explanation of ESD warning symbol and training in ESD precautionary procedures.

Contraindication

1. Do not use microwave ovens, microwave therapy apparatuses, or devices utilizing microwaves near this device. Failure to heed this warning may result in device malfunction.
2. Supervise and advise people not to bring mobile phones, transceivers, radio control toys, and other electronic devices into the room where this monitor is installed. Failure to heed this warning may result in device malfunction.
3. Do not use in an X-ray room, MRI room, or image processing room. Failure to heed this warning may result in device malfunction.
4. This device cannot be used in conjunction with an electrosurgical knife, defibrillator, or MRI. All probes and accessories must be removed before use of an electrosurgical knife, defibrillator, or MRI. Failure to heed this warning may result in damage to the device

Warning label

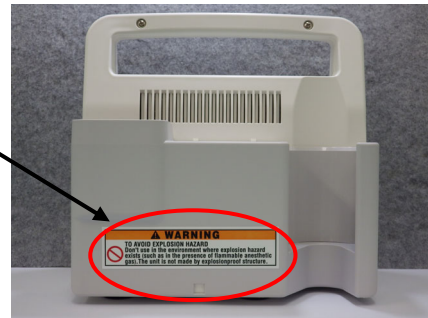

The following warning label is attached to the probe/gel holder to indicate an especially important precaution. Be sure to read the label before use.



DOPPLER FETUS DETECTOR
MODEL FD-492
Power Source 100-240 VAC,50/60Hz
30VA

SN

Protection Class II & Internally
Powered Equipment and Type B ↑

TOITU CO.,LTD.  
1-5-10,Ebisu-Nishi,Shibuya-Ku, Tokyo, _____ 1 6 3 9
150-0021,Japan MADE IN JAPAN

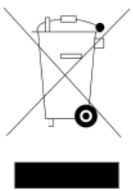



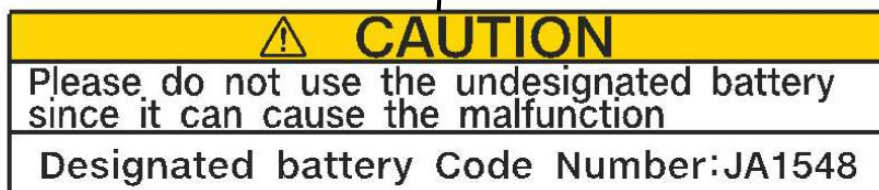







This symbol indicates that this product comes under the provisions of EU Directive 2002/96/EC on waste electrical and electronic equipment (WEEE) and that this unit was placed on the market after 12 August 2005. This directive covers EOL (end-of-life) disposal.







Meaning of Symbols

Symbols

1. Symbols of the IEC International Standard and the Japanese Industrial Standards

	Class II device		Input
	Functional ground		
	Attached part type B		Alternate current
	Fuse		Device sensitive to static electricity
	Caution		Non-ionizing radiation

2. Toitu symbols

	Radio wave condition		Battery symbol
	Earphone		Abnormality indicator of probe

Electromagnetic Compatibility (EMC)

MEDICAL ELECTRICAL EQUIPMENT needs special precautions regarding EMC and needs to be installed and put into service according to the EMC information provided in this document.



WARNING

Portable RF communications equipment (including peripherals such as antenna cables and external antennas) should be used no closer than 30 cm (12 inches) to any part of the FD-490, including cable specified by the manufacturer. Otherwise, deviation of the performance of this equipment could result.

The FD-490 should not be used adjacent to, or stacked with, other equipment. If adjacent or stacked use is necessary, the equipment or system should be tested to verify normal operation in the configuration in which it is being used.

This device complies with the EMC standard IEC 60601-1-2:2014/ EN 60601-1-2:2015.

Essential Performance

The Essential Performance for FD-490 is as follows.

- To examine the fetal heartbeat in early, middle and late pregnancy using Doppler technology

The following phenomena are expected when the Essential Performance is lost or degraded.

- Technical alarm
- No waveforms and/or numeric values
- Noise is heard in the Doppler sound
- The device has a complete failure

Guidance and Manufacturer's Declaration - Electromagnetic Emissions

The FD-490 is intended for use in the electromagnetic environment specified below.
The customer or the user of the FD-490 should assure that it is used in such an environment.

Emissions test	Compliance	Electromagnetic environment - guidance
RF Emissions CISPR 11	Group 1	The FD-490 uses RF energy only for its internal function. Therefore, its RF emissions are very low and are not likely to cause any interference in nearby electronic equipment.
RF Emissions CISPR 11	Class B	The FD-490 is suitable for use in all establishments, including domestic establishments and those directly connected to the public low-voltage power supply network that supplies buildings used for domestic purposes.
Harmonic Emissions IEC 61000-3-2	Class A	
Voltage Fluctuations/ Flicker Emissions IEC 61000-3-3	Complies	

Guidance and Manufacturer's Declaration - Electromagnetic Immunity

The FD-490 is intended for use in the electromagnetic environment specified below.
The customer or the user of the FD-490 should assure that it is used in such an environment.

Immunity test	IEC 60601 Test Level	Compliance Level	Electromagnetic environment - guidance
Electrostatic Discharge (ESD) IEC 61000-4-2	±8 kV contact ±2 kV, ±4 kV, ±8 kV, ±15 kV air	±8 kV contact ±2 kV, ±4 kV, ±8 kV, ±15 kV air	Floors should be wood, concrete or ceramic tile. If floors are covered with synthetic material, the relative humidity should be at least 30%.
Electrical Fast Transient/Burst IEC 61000-4-4	±2 kV for power supply lines ±1 kV for input/output lines	±2 kV for power supply lines Not applicable	Mains power quality should be that of a typical commercial or hospital environment.
Surge IEC 61000-4-5	±0.5 kV, ±1 kV line (s) to line (s) ±0.5 kV, ±1 kV, ±2 kV line (s) to earth	±0.5 kV, ±1 kV line (s) to line (s) ±0.5 kV, ±1 kV, ±2 kV line (s) to earth	Mains power quality should be that of a typical commercial or hospital environment.
Voltage dips, short interruptions and voltage variations on power supply input lines IEC 61000-4-11	0% U _T : 0.5 cycle At 0°, 45°, 90°, 135°, 180°, 225°, 270° and 315° 0% U _T : 1 cycle and 70% U _T : 25/30 cycles Single phase: at 0° 0% U _T : 250/300 cycle	0% U _T : 0.5 cycle At 0°, 45°, 90°, 135°, 180°, 225°, 270° and 315° 0% U _T : 1 cycle and 70% U _T : 25/30 cycles Single phase: at 0° 0% U _T : 250/300 cycle	Mains power quality should be that of a typical commercial or hospital environment. If the user of the FD-490 requires continued operation during power mains interruptions, it is recommended that the FD-490 be powered from an uninterruptible power supply or a battery.
Power Frequency (50/60 Hz) Magnetic Field IEC 61000-4-8	30 A/m	Not applicable NOTE 2	Power frequency magnetic fields should be at levels characteristic of a typical location in a typical commercial or hospital environment.

NOTE 1: U_T is the a. c. mains voltage prior to application of the test level.

NOTE 2: This test is not applied (N/A). Because this EUT is not magnetically sensitive.

Test specifications for ENCLOSURE PORT IMMUNITY to RF Wireless communications equipment

WARNING: Portable RF communications equipment (including peripherals such as antenna cables and external antennas) should be used no closer than 30 cm (12 inches) to any part of the FD-490, including cable specified by the manufacturer. Otherwise, deviation of the performance of this equipment could result.

Test frequency (MHz)	Band (MHz)	Service	Modulation	Maximum Power (W)	Distance (m)	Immunity Test Level (V/m)
385	380-390	TETRA 400	Pulse modulation 18 Hz	1.8	0.3	27
450	430-470	GMRS 460, FRS 460	FM ± 5 kHz deviation 1 kHz sine	2	0.3	28
710	704-787	LTE Band 13, 17	Pulse modulation 217 Hz	0.2	0.3	9
745						
780						
810	800-960	GSM 800/900, TETRA 800, iDEN 820, CDMA 850, LTE Band 5	Pulse modulation 18 Hz	2	0.3	28
870						
930						
1720	1700-1990	GSM 1800; CDMA 1900; GSM 1900; DECT; LTE Band 1, 3, 4, 25; UMTS	Pulse modulation 217 Hz	2	0.3	28
1845						
1970						
2450	2400-2570	Bluetooth, WLAN, 802.11.b/g/n, RFID 2450, LTE Band 7	Pulse modulation 217 Hz	2	0.3	28
5240	5100-5800	WLAN 802.11 a/n	Pulse modulation 217 Hz	0.2	0.3	9
5500						
5785						

Radio Wave Information

This device uses a radio wave frequency of 2.4GHz. Many systems operate within this frequency band— industrial, scientific, or medical devices; microwave ovens; and on premises radio stations for mobile identification on the manufacturing lines in factories that require a license, specified low power radio stations that require no license, and amateur radio stations, (hereinafter called as “other radio stations”). This device uses the full band of 2.4GHz and cannot avoid the band of systems for mobile identification. The FH-SS system is employed as the method of modulation, and a distance of 10 m or less may cause interference.



[2.4]	Radio wave frequency of 2.4GHz
[FH]	FH-SS system
[1]	Distance of 10 m or less may cause interference
	Uses the full band of 2.4GHz and cannot avoid the band of systems for mobile identification

Remarks: Precautions for use of common wireless devices

1. Make sure that no other radio stations are near the device before use.
2. If there is any harmful radio wave interference between other radio stations, immediately change the frequency of this device, change the location, or stop operation (stop transmission of radio waves).
3. Contact us or distributor in the event of any problems, such as radio wave interference.

Table of Contents

Introduction	I
For Safe and Proper Use	II
List of Warnings	III
Meaning of Symbols	VI
Electromagnetic Compatibility (EMC)	VII
Radio Wave Information	XII
1. Summary	1
1-1. Features	1
1-2. Principles	2
2. List of Components	3
2-1. Wired Type	3
2-2. Wireless Type	3
3. Part Names and Functions	4
3-1. Main Unit	4
3-2. Probe	9
4. Preparations	11
4-1. How to attach/remove the Rechargeable Battery	11
4-2. Wired Type	12
4-3. Wireless Type	13
5. How to Use	18
5-1. Usage Environment	18
5-2. Charging the Main Unit	19
5-3. Turn on the Power	20
5-4. Inspection before Use	21
5-5. Apply ultrasound gel	23
5-6. Measurement	24
5-7. After Measurement	27
5-8. Standby Mode	28
5-9. Isolation from supply mains	29
6. Functions	30
6-1. Display Function	30
7. Settings	32
7-1. No Signal Power Off	33
7-2. Automatic Power Off	34
7-3. Timer Setting	34
7-4. Buzzer Volume	35
7-5. Date and Time	36
7-6. Operation Sound	38

7-7. Brightness of Backlight	39
7-8. Languages	39
7-9. Sweep Rate	40
7-10. Wireless Off Timer (Wireless Type Only)	40
8. Cleaning/Inspection/Storage	42
8-1. Cleaning	42
8-2. Inspection	45
8-3. Storage	50
9. Troubleshooting	51
9-1. Wired Type	52
9-2. Wireless Type	54
10. Specifications	56
10-1. Product Specifications	56
10-2. Accessories	59
10-3. Usable service life/Warranty/Disposal	60
10-4. Service parts	60
Notification to Users	61

1. Summary

The FD-490 is a handheld Doppler fetus detector used by physicians or medical professionals under the direction of a physician to examine fetal heart sounds, sounds of umbilical blood flow, or fetal position. It is used to confirm the fetal well-being. This device consists of the main unit and the probe. The main unit incorporates an LCD screen to display fetal heart rates and a speaker to amplify Doppler sounds. There are two types of probe: wired and wireless.



• Wired type



• Wireless type

1-1. Features

- User friendly display
Heart rate display was enlarged.
(Length and width are twice as large as the conventional Doppler fetus detector.)
Changes in heart rates can be identified in the waveform display by switching the screen.
- Touch panel operation
Control the volume and configure the settings simply by touching the screen.
- Waterproof probe
The probe is waterproof (IPx7).
The probe can be washed, allowing more hygienic use.

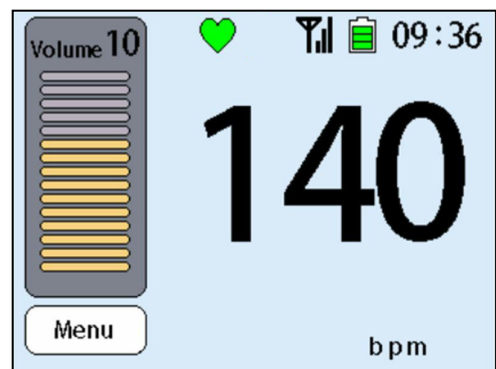

- Probes

Three types of probes are available as follows:

Use each type depending on the intended purpose.

- The wired type features a curled cord offering better maneuverability than previous models.
- The wireless type frees the operator and patient from having to worry about the cord during use.



- Wired type (Upright)
TR-205



- Wired type (L-shape)
TR-203



- Wireless type (L-shape)
TR-204

- Light and compact

The unit is light, compact, and easy to carry.

- Convenient power supply in two ways

The unit can be used with the internal battery when there is no electrical outlet in the area.

1-2. Principles

This device detects the fetal heart rate using ultrasound Doppler technology. When a high-frequency voltage is applied to the transmission element of the probe, the element vibrates and emits ultrasound waves. When these ultrasound waves reach the fetal heart through the maternal abdominal wall, the waves are reflected by the movement of the heart valves, blood flow, and fetal movement and return to the receiving element of the probe. The received waves are processed as signals and separated by differences between the heart-rate signal and the fetal movement signal. The Doppler sound caused by the fetal heart rate can be heard through the speaker because it is in the audible range.

2. List of Components

2-1. Wired Type



No.	Name	Quantity
1	Main unit	1
2	Wired probe (Choose TR-203 or TR-205)	1
	Connecting cord	1
3	Power cord	1

No.	Name	Quantity
4	Ultrasound Gel	1
-	Operation manual	1
-	-	-
-	-	-

2-2. Wireless Type



No.	Name	Quantity
1	Main unit	1
2	Wireless probe	1
3	Power cord	1
4	Alkaline battery (for operation check)	1

No.	Name	Quantity
5	Ultrasound Gel	1
-	Operation manual	1
-	Mini-Din connector cover	1
-	-	-

3. Part Names and Functions

3-1. Main Unit

1. Front and left side

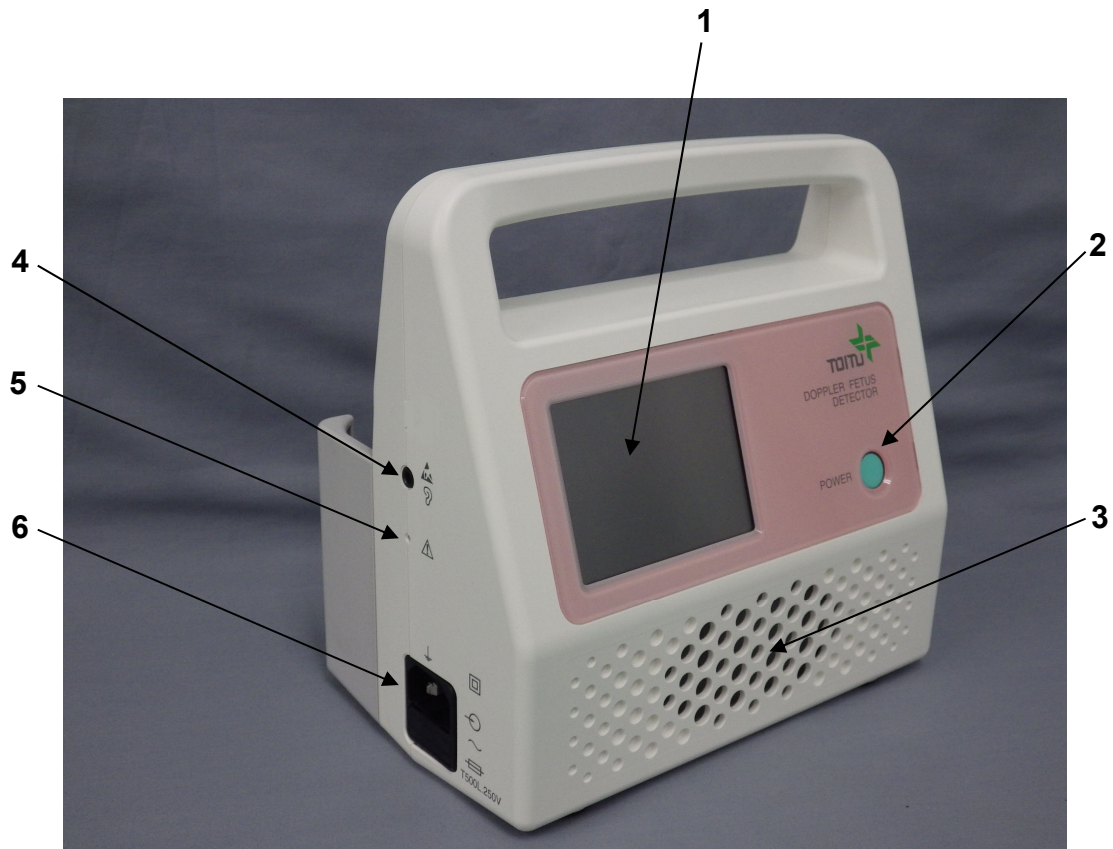

	Part names	Functions and operations
1	LCD screen	Displays heart rate and can be operated by a touch panel.
2	Operating switch	Turns power off and on. Used for the pairing procedure in the wireless type.
3	Speaker	Outputs Doppler sound and operation sounds.
4	Earphone jack	For connecting of an optional earphone.
5	Reset switch	Resets the device. See section 9 "Troubleshooting, Reset procedure."
6	Power inlet / fuse holder	Connects the power cord. Fuse is inside.

2. Back and right side

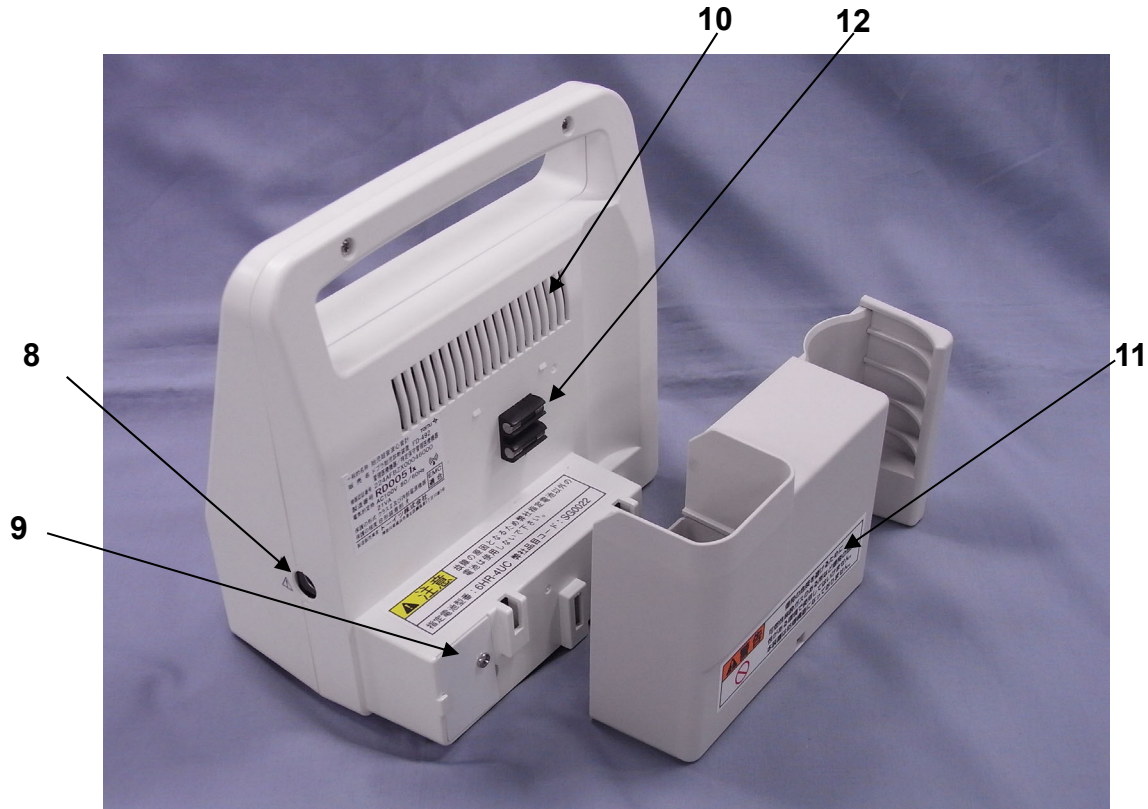

№	Part names	Functions and operations
8	Connector	Connects the wired probe. NOTE: When using the wireless probe, attach a Mini-Din connector cover to the connector.
9	Battery cover	Cover for the battery box. The special rechargeable battery is placed in the box.
10	Heat vent	Exhausts heat from inside the main unit.
11	Probe/gel holder	Holds the probe and Ultrasound Gel.
12	Spare fuse holder	Holds the spare fuse.

3. Display of heart rate

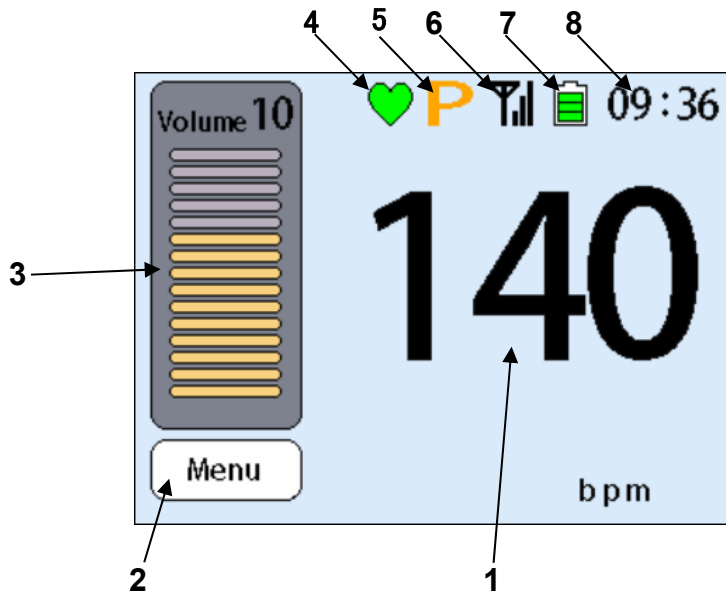

No	Part names	Functions and operations
1	Display of heart rate	Displays the measured heart rate.
2	Menu	Displays the setting display.
3	Volume meter	Controls the volume of Doppler sounds. Operation sounds and buzzer sounds are not affected.
4	Heart beat synchronization symbol	Lights in response to detection of the heartbeat.
5	Symbol of abnormality in probe	Displayed in response to an abnormality in the probe.
6	Symbol for radio wave strength	Displays the radio wave status and the pairing condition. Not displayed while using the wired probe.
7	Battery symbol	Displays the remaining rechargeable battery level and the charging condition.
8	Time	Time (hours and minutes) is displayed in 24-hour notation.

4. Waveform display

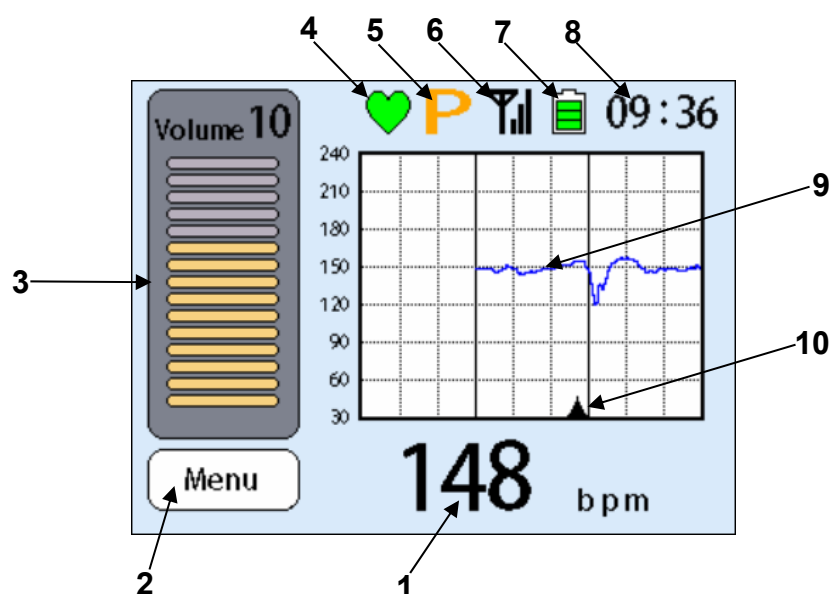



No	Part names	Functions and operations
1	Display of heart rate	Displays the measured heart rate.
2	Menu	Displays setting display.
3	Volume meter	Controls the volume of Doppler sounds. Operation sounds and buzzer sounds are not affected.
4	Heart beat synchronization symbol	Lights in response to detection of the heartbeat.
5	Symbol of abnormality in probe	Displayed in response to an abnormality in the probe.
6	Symbol for radio wave strength	Displays the radio wave condition and the pairing condition. Not displayed while using the wired probe.
7	Battery symbol	Displays the remaining battery level and the charging condition during operation of the main unit with the battery.
8	Time	Time (hours and minutes) is displayed in 24-hour notation.
9	Waveform display	Measured heart rate is displayed in waveform.
10	Event symbol	Displayed when pushing the operating switch during measurement.







5. Symbols

The symbols displayed on the LCD screen indicate the status of the device.

- Symbols for an abnormality in the transducer

	Blinking	Abnormality in transmission * E.g., the connection cord is unplugged
	Lighting	Low battery level in the wireless probe

- Symbols for radio wave strength

	Lighting	Radio wave strength (excellent)		Lighting	Radio wave strength (good)
	Lighting	Radio wave strength (fair)		Lighting	Now checking transmission
	Blinking	Now pairing		Lighting	<ul style="list-style-type: none"> • Radio wave strength (poor) • Pairing failure

- Battery symbols

	Blinking	Now charging		Lighting	Battery level (high)
	Lighting	Battery level (medium)		Lighting	Battery level (low)
	Lighting	No battery level		Blinking	Battery abnormality or breakdown

3-2. Probe

1. Wired probe (L-shape) TR-203

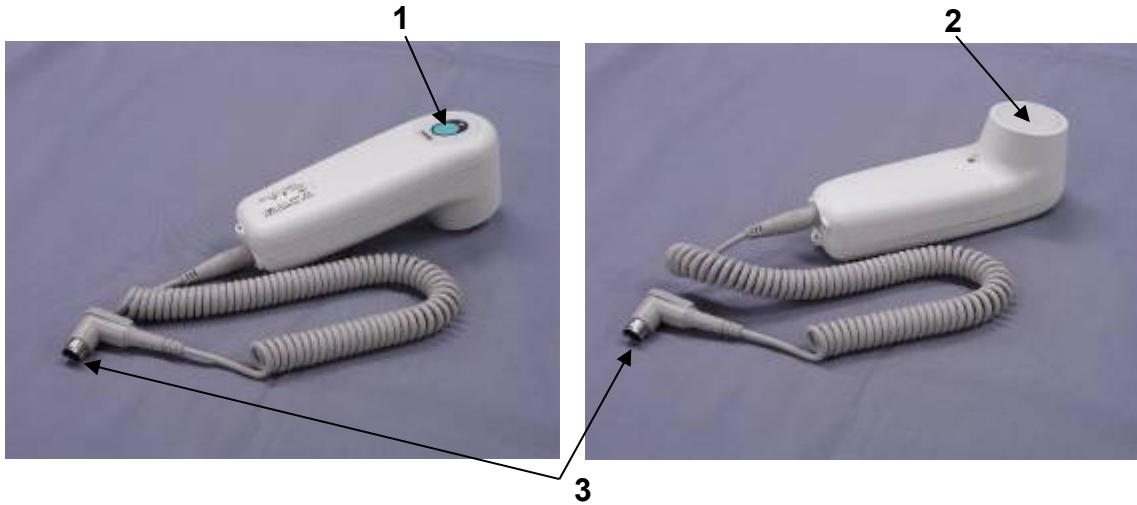

No	Part names	Functions and operations
1	Operating switch	Turns power off and on. LED indicates operating status. See section 3-2 “Probe, 4. Probe LED indications.”
2	Probe head	Sends and receives ultrasound when touching the maternal abdominal wall.
3	Connecting cord	Connects the wired probe to the main unit.

2. Wired probe (Upright) TR-205

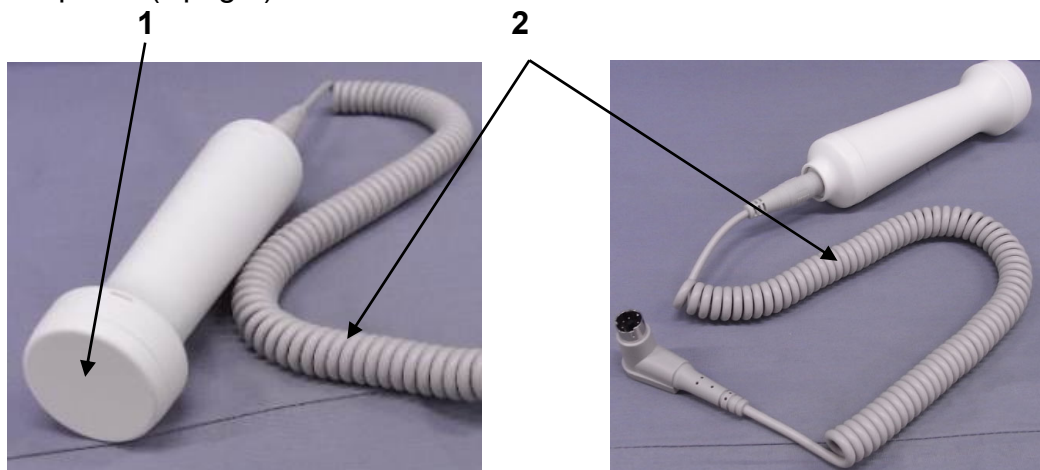





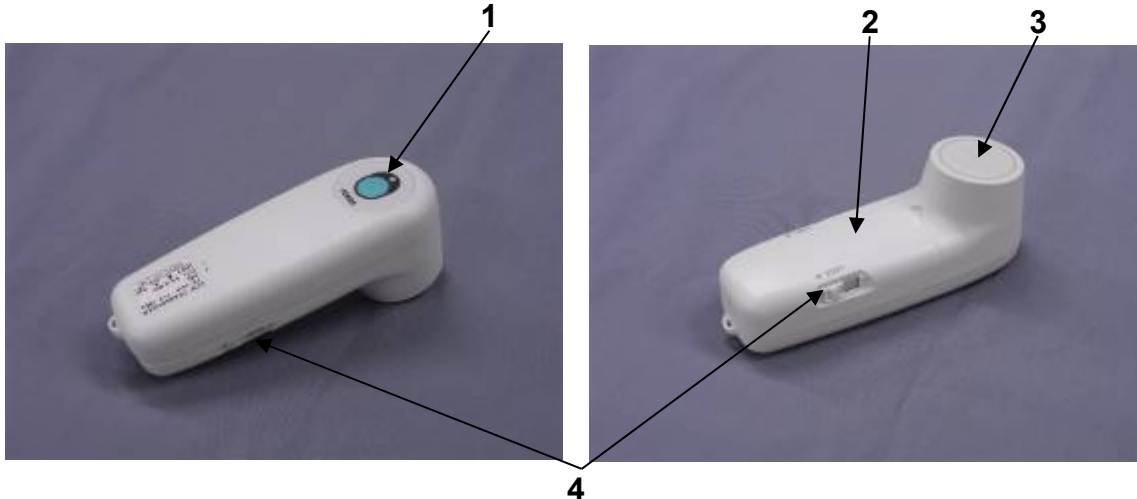

No	Part names	Functions and operations
1	Probe head	Sends and receives ultrasound when touching the maternal abdominal wall.
2	Connecting cord	Connects the wired probe to the main unit.

3. Wireless probe (L-shape only) TR-204



No	Part names	Functions and operations
1	Operating switch	Turns power off and on. LED indicates operating status. Used for pairing.
2	Battery cover	Cover for the battery box. Holds AA battery.
3	Probe head	Sends and receives ultrasound when touching the maternal abdominal wall.
4	Lock knob	Secures the battery cover.

4. Probe LED indications (L-shape only)

Common in wired/wireless types			Wireless type only		
	Lighting (blue)	Power on		Blinking (blue)	Now pairing
	No lighting	Power off		Blinking (red)	Battery level (low)
	Blinking (red and blue)	Transmission abnormality		Blinking every 5 seconds (blue)	Standby

4. Preparations



WARNING

- Attach or remove the battery after unplugging the power cord. Do not operate devices when wet or with wet hands. Failure to heed this warning may result in a breakdown of the device or electric shock.

4-1. How to attach/remove the Rechargeable Battery

- Attach the battery

1. Slip the probe/gel holder to the upper side for removal from the main unit.
You can see how to remove the holder in 8-1 “Cleaning: how to remove the holder.”



2. Remove the screw of the battery cover on the back of the main unit using a coin or a screwdriver.



3. Connect the connector in the battery box of the body and the rechargeable battery until they lock.

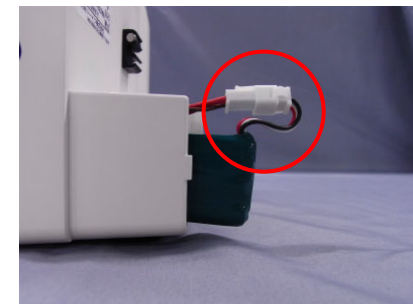

4. Push the connector and the rechargeable battery into the battery box.



5. Secure the battery cover with the screw and attach the probe/gel holder to the main unit.

- Removal of the battery

Pull the connector on the rechargeable battery while pushing the lock on the connector for the rechargeable battery from the upper side to remove the rechargeable battery.

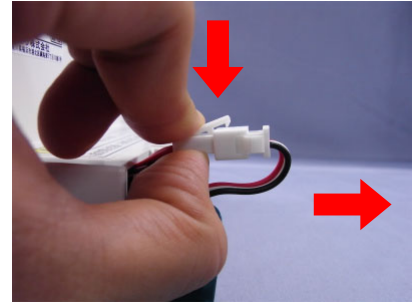

4-2. Wired Type



CAUTION

- Connect the wired probe while the power is turned off.

Note1: The wired probe and the wireless probe cannot be used at the same time. (The wired probe has priority.) When using the wireless probe, check that the wired probe is not connected to the main unit.

1. Connection of wired probe

When using the wired probe, connect the cord to the connector of the main unit. Insert the connector so that direction of the cord is upward.

Direction of the connection cord

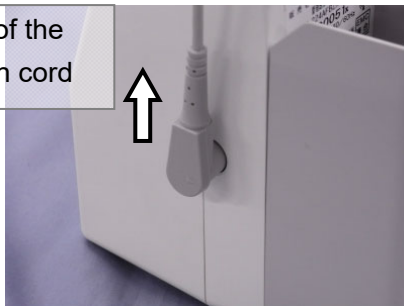

Insert the connector so the connection cord is upward.



The wired probe connected to the main unit.

2. Setting the time of the main unit

Set the time after attaching the rechargeable battery to the main unit.

- 1) Connect the power cord and turn on the power to the main unit according to 5-2 “Charging the Main unit” and 5-3 “Turn on the Power.”
- 2) Touch the Menu button in the lower left of the LCD screen of the main unit to display the setting display.

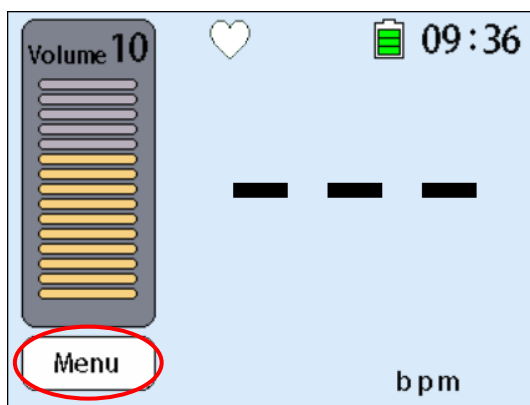

- 3) Set the time according to the procedures in 7-5 “Date and Time.”

4-3. Wireless Type

1. How to insert the battery

Insert the battery according to the following procedures.

The wireless probe requires an AA battery. Use an alkaline battery or an AA nickel metal-hydride rechargeable battery.

Note1: Attach a Mini-Din connector cover to the connector (See 3-1 Main Unit 2. Back and right sides) .

Note2: The battery can be replaced using the same procedures. Remove the Battery cover by pushing in the direction of the arrow as in the following picture. Do not press the battery cover while sliding the lock knob.



1) Release the lock to the battery cover. Slide the lock knob in the opposite direction from LOCK until it clicks.

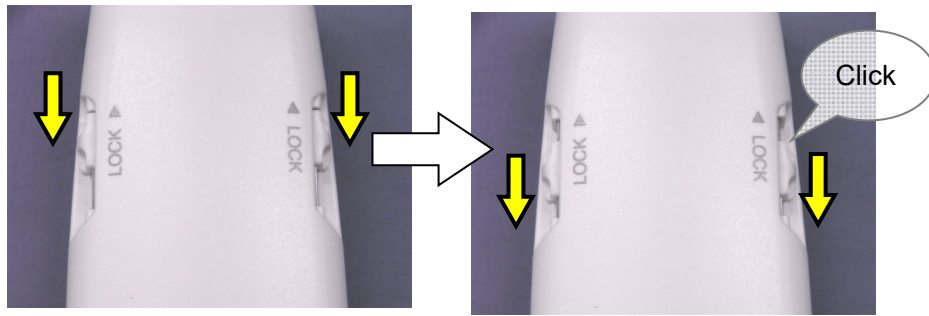

2) When sliding the lock knob to the end, the battery cover will lift slightly to make a space.

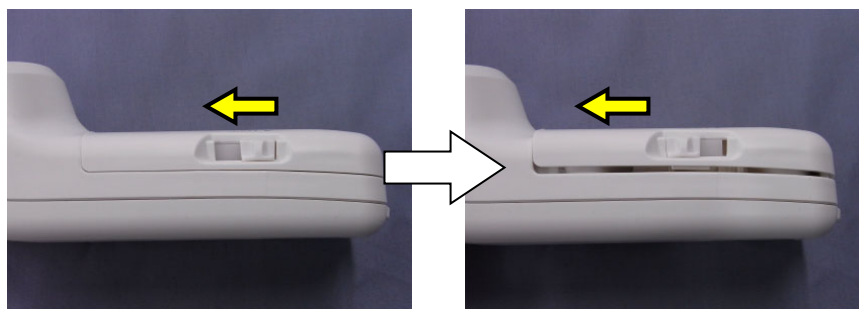

- Be careful not to press the battery cover with your fingers.

* If the lock knob will not slide easily, place the side of probe head on a flat surface and push down on the lock knob.



3) When the battery cover lifts up, remove the cover from the unit.



4) How to insert the battery

Pay attention to the direction of the AA battery and insert the minus (-) end first.

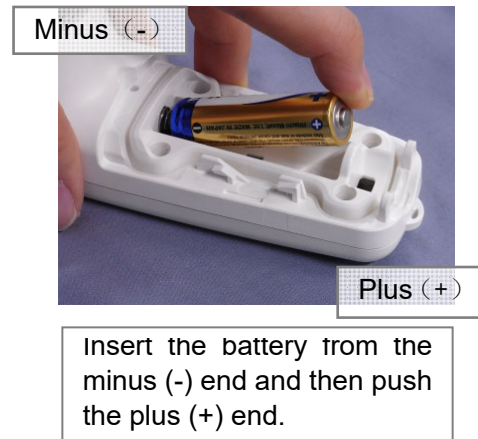
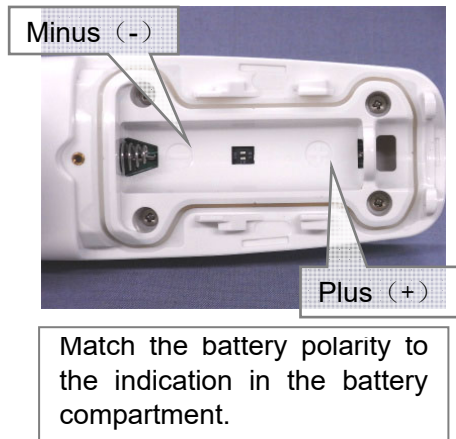

5) Attach the battery cover

When replacing the battery cover, push firmly until there is no space.

Slide the lock knob until clicks.



2. Pairing



- If two or more of these device are used in the same facility, check the pairing of the main unit and wireless probe. Failure to follow these instructions may result in a mix-up of patients.
- If there is a wireless device other than this device that may cause interference, consult us or distributor about measures to prevent such interference (e.g. installation of partitions).



CAUTION

- Place the main unit close to the wireless probe while pairing.
- Do not pair simultaneously when two or more devices are used in the same facility.

Pairing is a procedure to identify the combination of the main unit and the wireless probe.

Pair the device according to the following procedures.

Note:

Once you pair the device, you do not need to pair it again.

- Pairing procedures

Push both operating switches on the main unit and the wireless probe until the LCD screen on the main unit and the LED on the wireless probe are in operation.



Push both operating switches

- Operating switch on the main unit
- Operating switch on the wireless probe

When pairing starts, the symbol for radio wave strength in the upper area of the LCD screen blinks in blue. The LED of the operating switch on the wireless probe also blinks in blue. Lift your finger off the operating switches when pairing starts.



- Symbol for radio wave strength (blinks in blue)



- LED on the operating switch (blinks in blue)

- Check pairing

When pairing is complete, the symbol and the LED stop blinking, and the displays on the main unit and the wireless probe change.

Main unit:

Symbol for radio wave strength on the LCD screen is displayed in black.

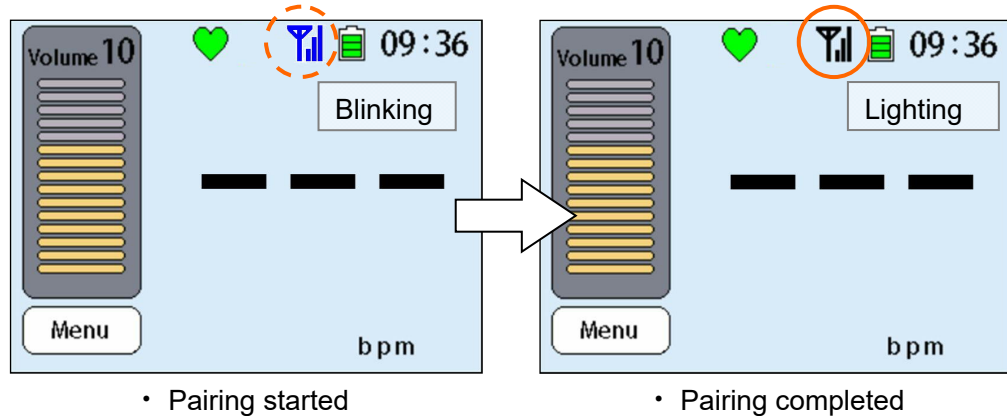

Wireless probe:

The LED on the operating switch lights in blue.

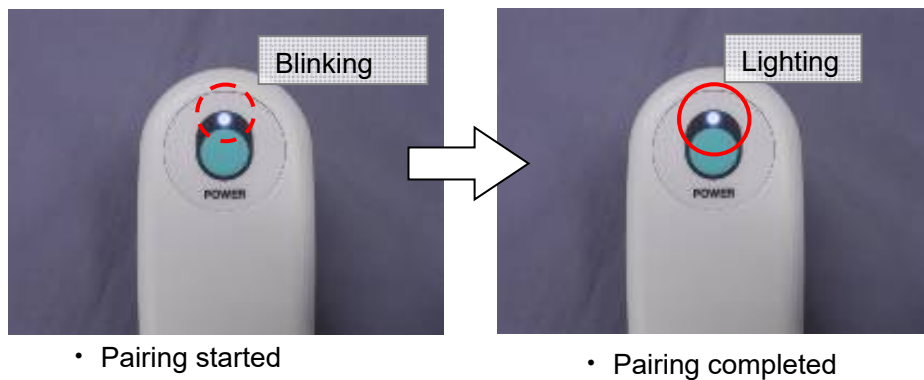

3. Setting time of the main unit

Set the time after attachment of the rechargeable battery onto the main unit.

- 1) Touch the button in the lower left of the LCD screen to display the setting display.

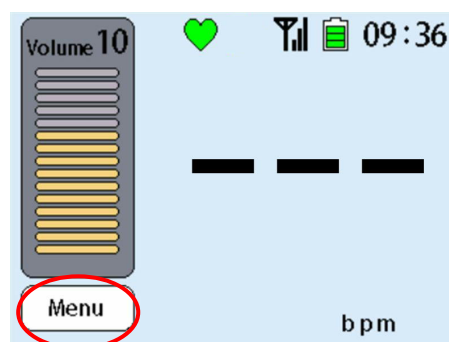

- 2) Set the time according to the procedures in 7-5 "Date and Time."

5. How to Use

5-1. Usage Environment



WARNING

- Do not use in a location where there is a risk of explosion, such as an environment with flammable anesthetic gas or oxygen.
- This device may cause poor transmission or interfere with other devices because of radio interference. Such interference requires changing the direction or installation location of this device or measures to reduce interference such as a shield.
- Use of accessories, probe, or cables other than the specified ones may cause an increase in emissions or reduce the resistance to interference of this device.
- If this device is used close to or stacked on top of another device, check the correct operation in the arrangement used.

Contraindication

- Do not use microwave ovens, microwave therapy apparatuses or devices utilizing microwaves near this device.
- Supervise and advise people not to bring mobile phones, transceivers, radio control toys, and other electronic devices into the room where this device is installed.
- Do not use in x-ray imaging rooms, MRI rooms, or image processing rooms.
- This device cannot be used in conjunction with an electrosurgical knife, defibrillator, or MRI. All probes and accessories must be removed before use of an electrosurgical knife, defibrillator, or MRI.



CAUTION

- Do not block the heat vent of this device.
- If a liquid is spilled on this device, stop using.
- Do not use this device in the strong high-frequency electromagnetic field, such as while using an electrosurgical knife.



CAUTION

Please do not use in the following locations as they may lead to problems with the device (e.g., malfunction, discoloration, stains.)

- Direct sunlight
- Moisture or dust
- Hot areas (over 40 °C)
- Cold areas (under 10 °C)
- Exposure to vibrations or unstable locations

Use this device under the following conditions:

- Temperature: 10-40 °C
- Relative humidity: 30-70% (No condensation)
- Atmospheric pressure: 700-1060hPa
- A room without the risk of an explosion
- Stable, flat location

5-2. Charging the Main Unit



WARNING

To avoid fire and electric shock

- Do not place heavy objects on the power cord. Do not damage, abuse, twist, pull, or heat the cord. In the event of damage to the power cord (exposed core or breakage), ask our office or distributor for an exchange.
(core wire exposed, broken).

To avoid electric shock

- Be sure to use the provided power cord. Other power cords may cause electric shock to the patient and the user.

The main unit incorporates a rechargeable battery. Check the battery level and charge regularly.

Note:

Low battery levels may result in the display of the wrong date and time.

1. Connection of the power cord
 - 1) Connect the power cord to the power inlet of the main unit.
 - 2) Insert the power plug into an AC outlet.



2. Charge

Charging starts automatically after connection of the power cord.

The Battery symbol starts blinking in the upper part of the LCD screen after the start of charging.

The Battery symbol changes from blinking to lighting after the device is fully charged.

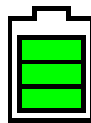

Battery symbol

5-3. Turn on the Power

1. Wired type

Push the operating switch on either the main unit or the wired probe until the LCD screen of the main unit and the LED of the wired probe light and then lift your finger off.



Push either of the operation switches



The LCD screen of the main unit and the LED of probe light when the power is on

2. Wireless type

Push the operating switches on both the main unit and the wireless probe until the LCD screen of the main unit and the LED of the wireless probe light and then lift your finger off.

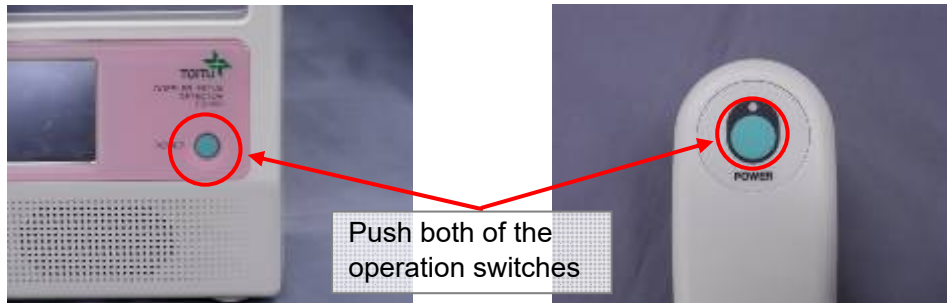

• Operating switch of the main unit

• Operating switch of the wireless probe



The LCD screen of the main unit and the LED of probe light when the power is on

5-4. Inspection before Use

1. Volume control



CAUTION

- Pay attention to the following points when operating the LCD screen (touch panel) of the main unit. Failure to heed this warning may result in a breakdown.
 - Do not dig fingernails into the screen. Do not operate with solid metal objects, such as a ballpoint pen.
 - Do not rub or push with excessive force.

The volume of this device can be controlled by touching the volume meter displayed in the left of the LCD screen. Slide your finger “up” to increase the volume and “down” to decrease the volume. The value for the volume and the yellow meter go up and down as the finger slides.

Reference:

If you set the volume to “00,” the Doppler sound is not output but there is no change in the volume of the operation sound and buzzer sound. To change the volume of these sounds, see 7-4 “Buzzer Volume” and 7-6 “Operation Sound.”

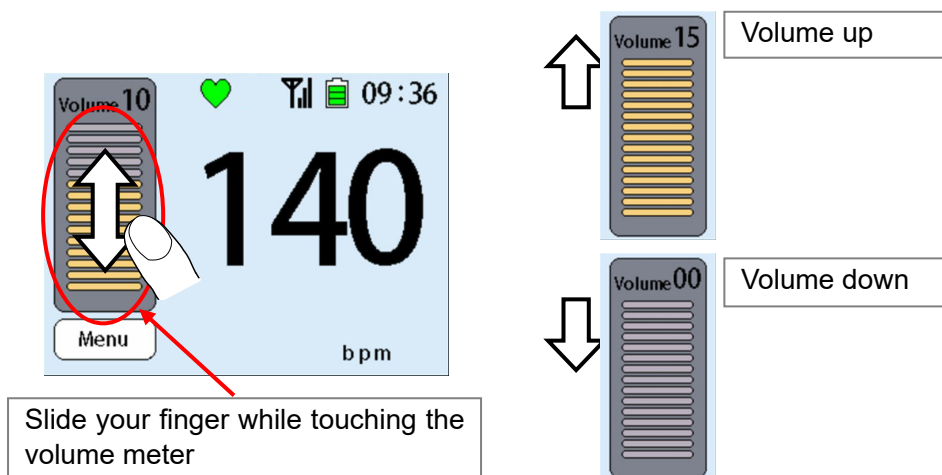

2. Check of signal detection



WARNING

To prevent misdiagnosis

- Do not use a probe that does not emit a Doppler sound.



CAUTION

- Do not expose the probe head of the probe to impacts or shocks. Doing so may result in an incorrect measurement or breakdown.

Check this device to detect signals and produce sounds from the speaker.

- 1) **Tap** the palm of the hand several times with the probe head.
- 2) Confirm that the speaker emits Doppler sounds.



5-5. Apply ultrasound gel

Apply the ultrasound gel to the surface of the maternal abdomen and the probe head. Too much or too little gel will not work well. Apply evenly in a thin layer.

Note :

This device incorporates a mute function. The mute prevents loud sounds when applying the gel to the probe head or moving across the abdominal wall. (Except TR-205)

5-6. Measurement



WARNING

To prevent misdiagnosis

- Adjust the probe to the optimum position in response to the movements of the fetus. If the unit firmly touches a maternal blood vessel, the probe will detect the maternal heart rate.
- If intrauterine fetal death is suspected by this test method, examine using another method.



CAUTION

- Poor reception of radio waves may interrupt the sound from the wireless probe. When determining the fixing point, hold the transducer so as not to cover the operation switch with the palm of the hand and adjust the angle.
- When using an earphone, pay attention to avoid raising the volume of the main unit too high.
- The wireless range of this device is within 10 m.
Measurements using the wireless probe may be less reliable than with the wired probe depending on the conditions, such as setting point and surrounding environment. Place the probe closer to the body of this device during use in such cases.
- The measurement time should be within 10 minutes and avoid keeping the probe in the same position for a long time.

1. Doppler sound

- 1) Touch the probe head firmly to the maternal abdominal wall.
Control the volume to the appropriate level.
- 2) Move slowly while touching firmly to detect the position that provides clear-cut rhythmic sounds (sounds of heart wall and valves).
- 3) The Doppler sound may be faint in the early pregnancy period.
You can hear more easily by using the optional earphone in such cases.

2. Display of heart rates

- 1) Detected heart rates are displayed on the LCD screen of the main unit.
- 2) The display becomes unstable after detection of the placenta and blood flow.
Search the optimal position that provides clear-cut rhythmic sounds in response to the movements of the fetus.

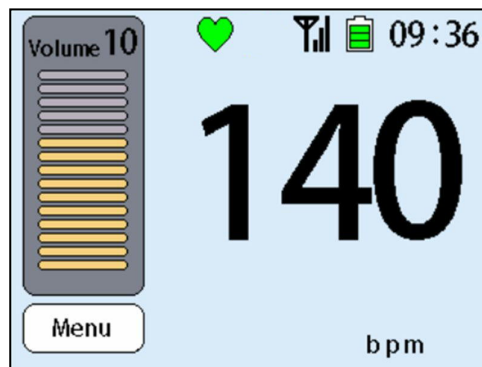

• Display of heart rates

3. If you cannot measure successfully

During the early pregnancy period:

- Start searching from a position two fingerbreadths from the superior margin of the symphysis pubis in the middle of abdomen.
- Detection is easier by checking the position of the uterus on palpation before starting.

During mid to late pregnancy period:

- Utilize the knowledge of the Traube stethoscope as is.
E.g. In the vertex position, search the position 1/3 of the distance from the navel-spine line of the fetal back side. If you cannot detect the heart rate, search three fingerbreadths from the superior margin of the symphysis pubis in the middle of the abdomen.

4. Detection for locations of the placenta and umbilical cord

Audible sounds differ by blood flow. Compare the Doppler sounds during detection of blood flow.

- Blood flow sound of Placenta

The sound is emitted as a continuous sound "GOH".

When the position of placenta is on back wall, possibility for detection is lower than the case on anterior wall.

- Blood flow sound of umbilical cord:

The sound "HYUH" "HYUH" is emitted from the blood flow of umbilical cord in Synchronization with fetal heart beats.

5-7. After Measurement

1. Turn off the power

Turn off the power by pushing the operating switch on either of the main unit or the probe (L-shape) until the LCD screen of the main unit goes out.

2. Wipe off the ultrasound gel

Wipe the ultrasound gel from the maternal abdominal wall and the probe with tissues or a soft cloth. The probe is waterproof and can be washed with water. See 8-1 “Cleaning” for washing with water.

* The main unit is not waterproof.

3. Storage

Place the used probe and the ultrasound gel in the probe/gel holder on the back of the main unit.

Probe:

Place the probe from the side of probe head as shown in the following pictures. Do not push the probe head in the direction of the back of the main unit. Doing so may damage the device. For the wireless probe, do not place it from the side of the battery box. If you do, the device may fall when carried.



• Correct storage of the probe



• Improper storage of the probe

Ultrasound gel: You can store the ultrasound gel in the probe/gel holder on the back of the main unit. The gel can be stored on both the upper or lower side.

Probe holder



Gel holder

Storage of the ultrasound gel

5-8. Standby Mode

You can change the power on and the standby mode of the device with the operating switch of the wireless probe with setting of the “7-10. Wireless Timer Off”.

- How to use the standby mode

1. Turn on the power

Push the operating switches of the main unit and the wireless probe.

See 5-3 “Turn on the Power ; 2. Wireless type” for instructions on how to turn on the power.

2. Set the standby mode

Push the operating switch of the wireless probe until the indicator goes out.

The radio wave strength symbol is displayed on the LCD screen during standby.

The LED of the operating switch of the wireless probe blinks in blue every five seconds.

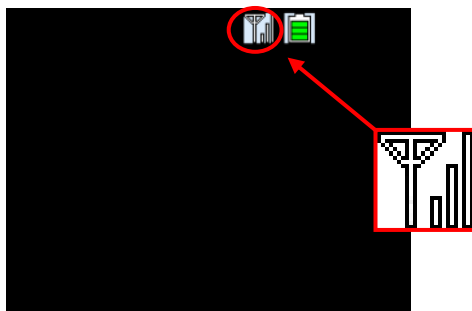

- Display of standby of the main unit (Display of the symbol for radio wave strength)



- Display of standby of the wireless probe (LED of the operating switch blinking in blue)

3. Turn on the power during standby

Push the operating switch of the wireless probe until the LED lights.

4. Turn off the power

Push the operating switch of the main unit until the display goes out.

5-9. Isolation from supply mains

1. Remove the power plug from an AC outlet.
2. Remove the power cord from the power inlet of the main unit.



6. Functions

6-1. Display Function

1. Display switching

When touching the following areas on the LCD screen of the main unit, the display switches to 1) Heart rate display, 2) Waveform display and 3) Waveform display (enlarged) in turn.

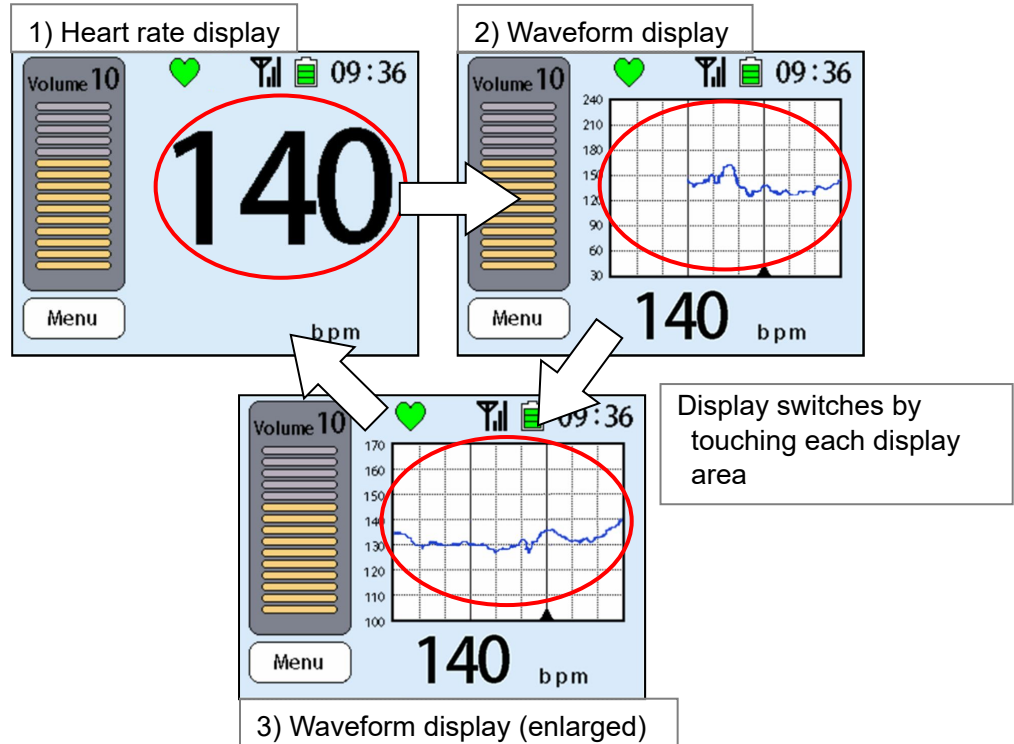

2. Heart rate display

Measured heart rates are displayed in numbers.

3. Waveform display

- Display area

Measured heart rates are displayed in a waveform. The heart rate is on the vertical ordinate and the measurement time is on the horizontal ordinate. The display changes in intervals of 10 mm/min, 20 mm/min, or 30 mm/min according to the setting for the sweep rate and transits from right to left. The displayed measurement time is 9 minutes, 4 minutes and 30 seconds, and 3 minutes, respectively. See 7-9 "Sweep Rate" for details on the setting.

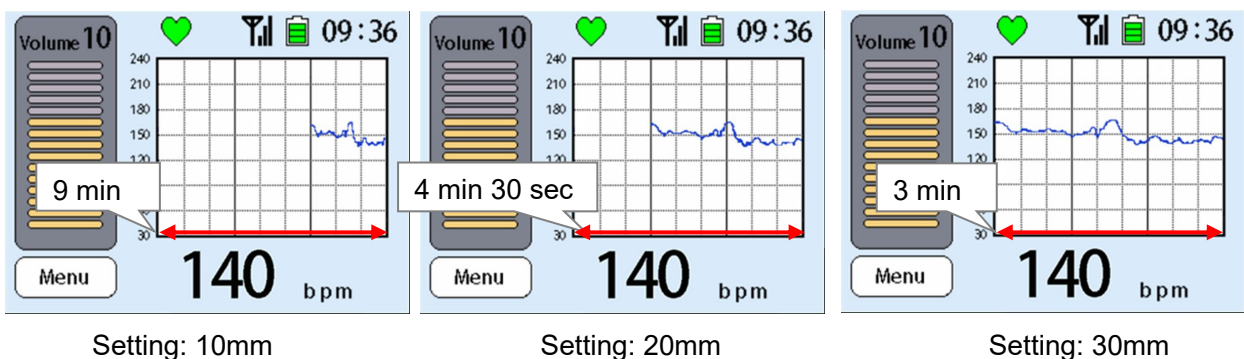

- Enlarged display

The waveform for measured heartbeats is enlarged. The enlarged display shows the heart rates of 100–170bpm and the measured time of 1 minute (setting: 30 mm), 1 minute and 30 seconds (setting: 20 mm), or 3 minutes (setting: 10 mm) depending on the setting of the sweep rate. See 7-9 “Sweep Rate” for details about the setting.

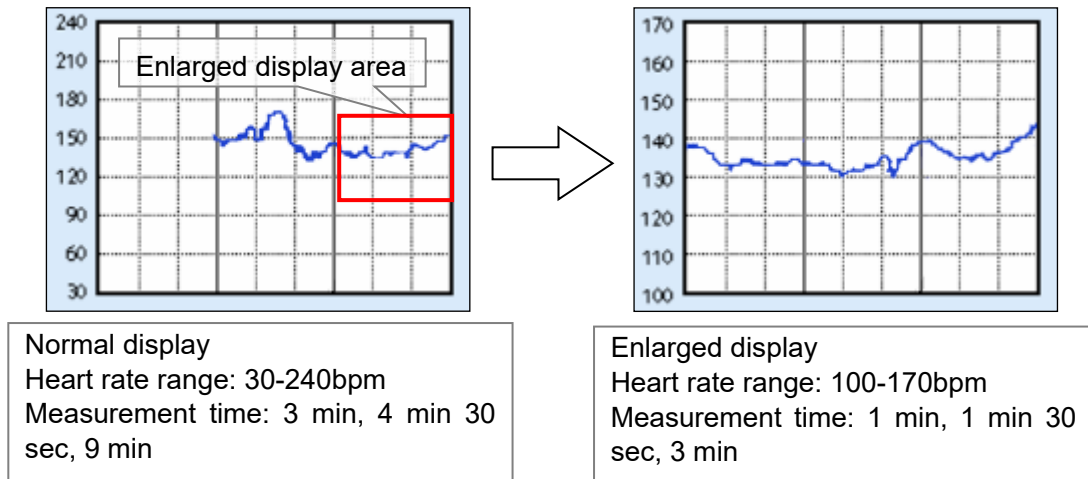

- Events

Push the operating switch of the main unit or the probe during the Waveform display and lift your finger immediately. The event symbol “▲” is displayed in the waveform display area. You can easily follow up the event such as labor pains by timely display of the event symbols.

Only one event symbol can be displayed on the waveform display area. If you push the operating switch again after an event symbol is displayed, the previous symbol is no longer displayed, and a new one is displayed on the right in the display area.

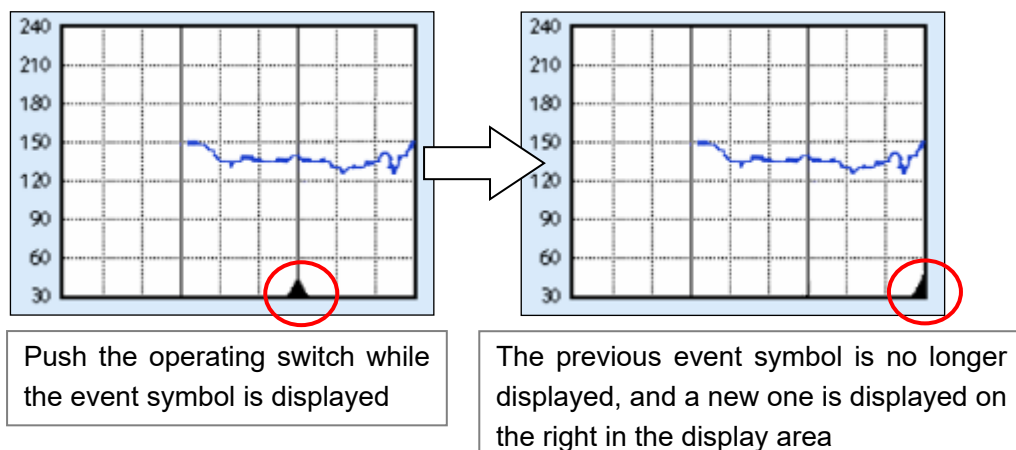

7. Settings



CAUTION

- Pay attention to the following points in operation of the LCD screen (touch panel) of the main unit. Failure to follow these operations may result in a breakdown.
 - Do not dig fingernails into the screen. Do not operate with solid metal objects, such as a ballpoint pen.
 - Do not rub or push with excessive force.

The settings for power-saving function, operation sounds, and date and time can be changed. The setting display can be displayed by touching the **Menu** button in the lower left area on the LCD screen of the main unit.

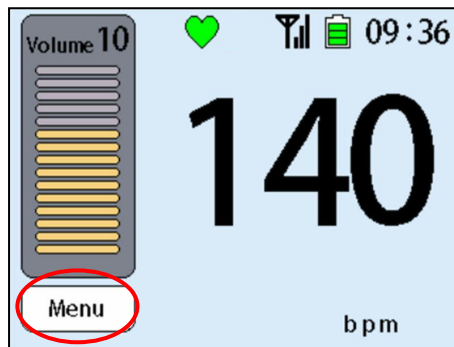

- Touch the **Menu** button to display the setting display

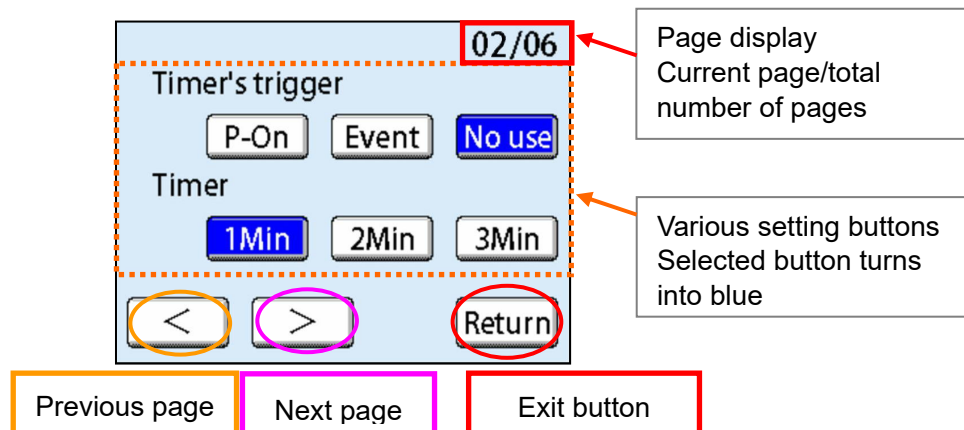

- Display and operating buttons for the setting display

Touch the setting button to make changes on the menu screen. The selected item turns blue and the setting change is reflected. Touch the **Return** button after making the adjustment to return to the measurement screen. When changing several settings, move to the other pages using the **<** and **>** buttons in the lower area without touching the **Return** button.

The menu consists of seven screens in total.

Move to the following screens to change the appropriate setting.

Menu screen: Table of contents

7-1. **No Signal Power Off** _____ (1/7)
 7-2. **Automatic Power Off** _____ (1/7)
 7-3. **Timer Settings** _____ (2/7)
 7-4. **Buzzer Volume** _____ (3/7)
 7-5. **Date and Time** _____ (4/7)
 7-6. **Operation Sound** _____ (5/7)
 7-7. **Brightness of Backlight** _____ (5/7)
 7-8. **Languages** _____ (6/7)
 7-9. **Sweep Rate** _____ (6/7)
 7-10. **Wireless Off Timer** _____ (7/7)

*(x/7) is the displayed on the upper right on the LCD screen

7-1. No Signal Power Off

This function turns the power off when there is no signal (the heart rate display is "--") after a predetermine amount of time. The initial (default) setting is to turn off the power after 2 minutes of no signal for the heart rate.

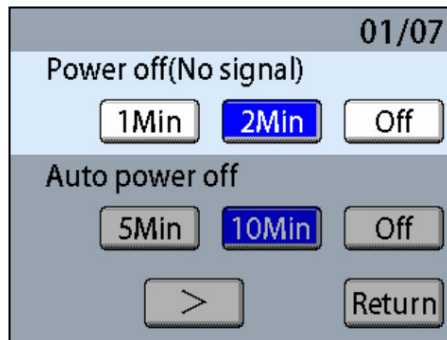

Setting	Details	Initial setting
1 Min	Turn off the power after 1 minute of no signal.	
2 Min	Turn off the power after 2 minutes of no signal.	O
Off	The power is not turned off even in the continuous no signal condition.	

7-2. Automatic Power Off

This function turns off the power at the set time during operation of the monitor. The power will turn off even in the middle of a measurement. The initial setting is 10 minutes.

* The setting is canceled in the standby mode.

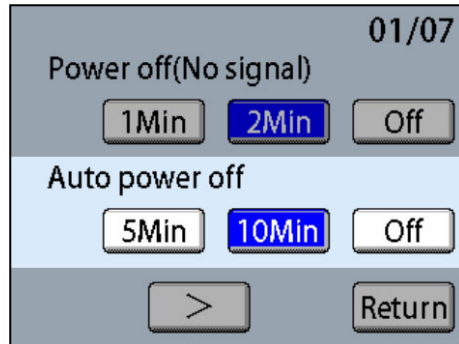

Setting	Details	Initial setting
5 Min	Turn off the power automatically 5 minutes after power on.	
10 Min	Turn off the power automatically 10 minutes after power on.	O
Off	The power is not turned off automatically.	

7-3. Timer Setting

When the set time has passed after the start of the timer, the device informs the user with a buzzer sound.

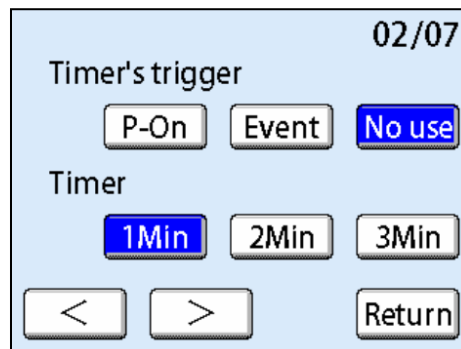

- Timer start

Setting	Details	Initial setting
P-On	Timer starts at power on.	
Event	Timer starts from input of event via the operating switch.	
No use	No timer function is used.	O

- Timer

Setting	Details	Initial setting
1 Min	Buzzer rings 1 minute after the set time.	O
2 Min	Buzzer rings 2 minutes after the set time.	
3 Min	Buzzer rings 3 minutes after the set time.	

- Timer start – event

Timer starts by pushing the operating switch during a measurement.

In the trend display, the event symbol “▲” is displayed in the waveform display area.

For example, in case of 1 minute (sweep rate: 30 mm) on the timer in 7-3”Timer Setting”.

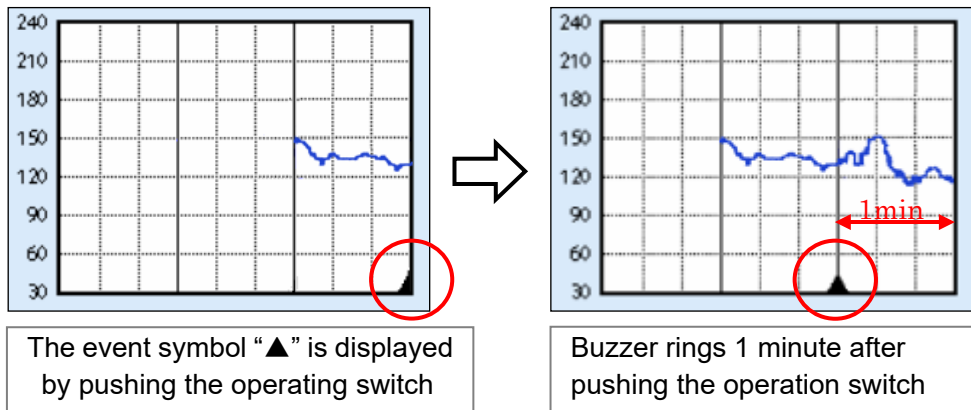

7-4. Buzzer Volume

Check the setting of the buzzer volume and set the volume as per user preference.

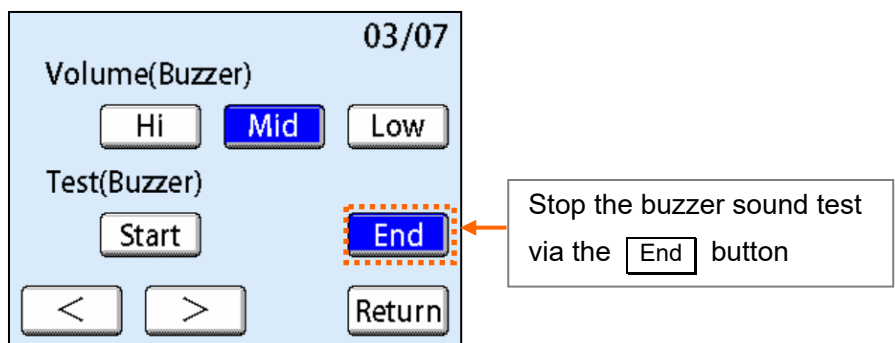

- Buzzer volume

Setting	Details	Initial setting
Hi	Loud volume	
Mid	Medium volume	O
Low	Low volume	

- Buzzer sound test

Buzzer rings at the set volume after touching the **Start** button.

The buzzer sound stops after touching the **End** button for the buzzer sound test.

7-5. Date and Time

Set the date and time.

The software keyboard is displayed by touching the input box for date and time. Enter the appropriate date and time.

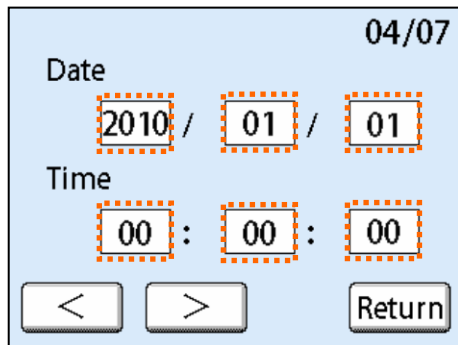

Touch the input box for date and time

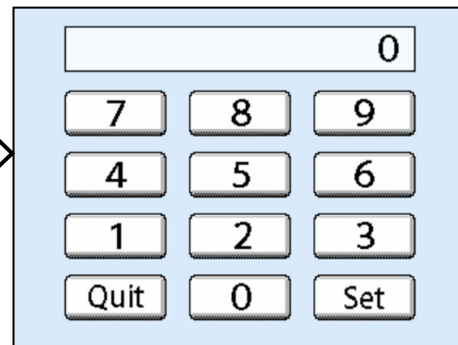

The software keyboard is displayed

1. Setting the date (e.g. June 23, 2012)

1) Touch the input box for "year". The software keyboard appears.

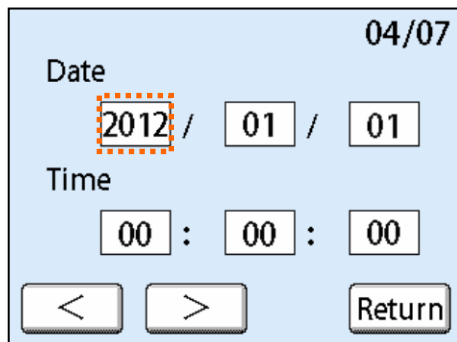

Touch the input box for "year"

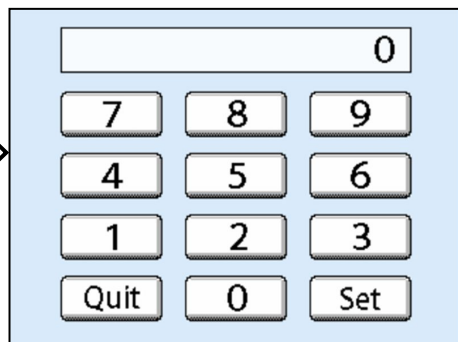

The software keyboard is displayed

2) Type "12" and touch **Set** button. The change is reflected in the setting display.

* Enter only the last two digits of the year.

Years from "00 to 99 (2000 to 2099)" can be entered.

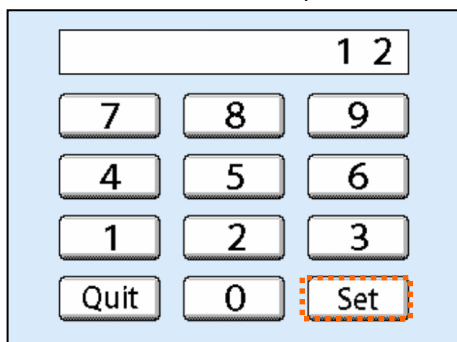

Type "12" and touch **Set** button

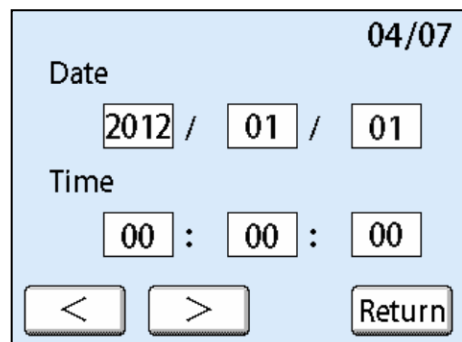

"2012" is reflected in the setting display

3) Set "month" and "day" using the same procedure.

* Enter "1-12" in the input box for "month."

* Enter "1-31" in the input box of "day."

You can enter up to 30 for a month of 30 days, up to 28 for February, and up to 29 in a leap year.

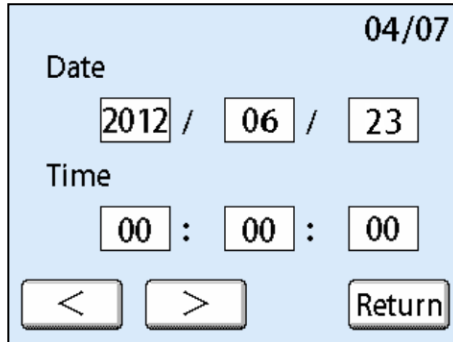

4) Touch the **Return** button after changing the setting to return to the measurement display.

2. Setting the time (e.g. 12:23:00)

1) Touch the input box for "hour." The software keyboard is displayed.

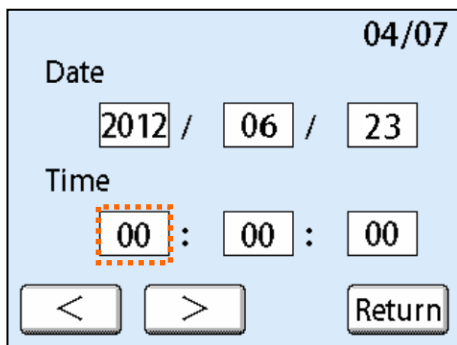

Touch the input box for "hour"

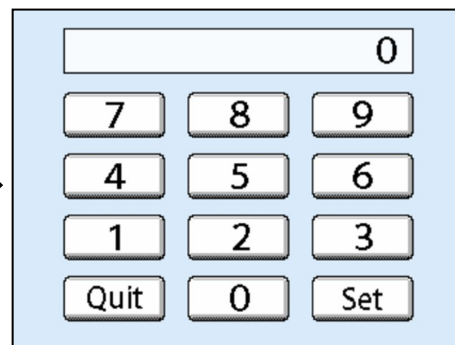

The software keyboard screen is opened

2) Type "12" and touch **Set**. The change is reflected in the setting display.

* Type "0-23" in the input box for "hour."

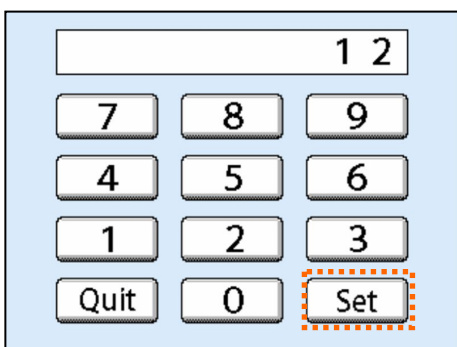

Type "12" then touch **Set** button

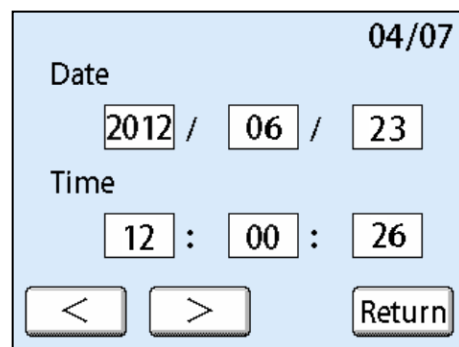

"12" is reflected in the setting display

- 3) Set “minutes” using the same procedure.
 * Enter 0-59” in the input box for “minutes.”

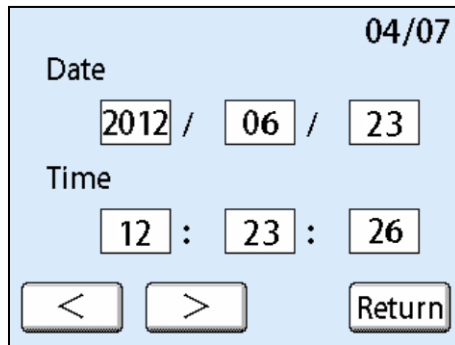

- 4) When you touch the box for “seconds,” the displayed value is reset to “00.”
 * The software keyboard is not displayed by touching the input box for “seconds” in contrast to other boxes.

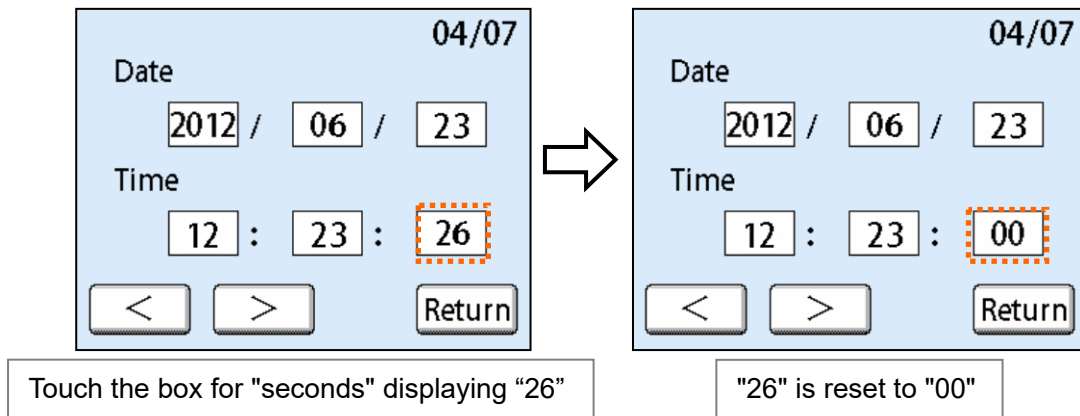

- 5) Touch the button after changing the setting to return to the measurement display.
 * The setting is reflected by touching the button or the or button.

7-6. Operation Sound

Operation sounds can be turned on or off. Select to activate operation sounds and to mute operation sounds.



Setting	Details	Initial setting
On	Provides operation sounds.	O
Off	Provides no operation sounds.	

7-7. Brightness of Backlight

Set the brightness of the LCD screen.

Select **Dim** for a darker screen, **Bright** for a brighter screen.

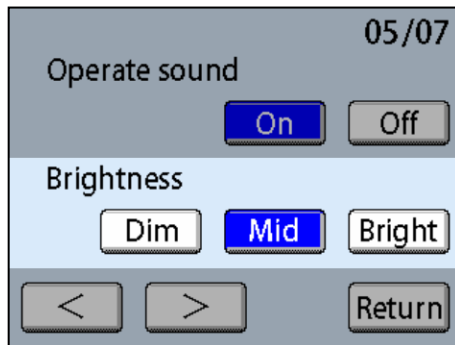

Setting	Details	Initial setting
Dim	Dims the backlight brightness.	
Mid	Sets backlight brightness to the middle level.	O
Bright	Brightens the backlight brightness.	

7-8. Languages

Select the language on the LCD screen. The options are Japanese and English.



Setting	Details	Initial setting
Japanese	Displays in Japanese.	
English	Displays in English	O

7-9. Sweep Rate

Set the sweep rate in the waveform display for the heart rate. When changing the sweep rate, the data is reset during measurement.

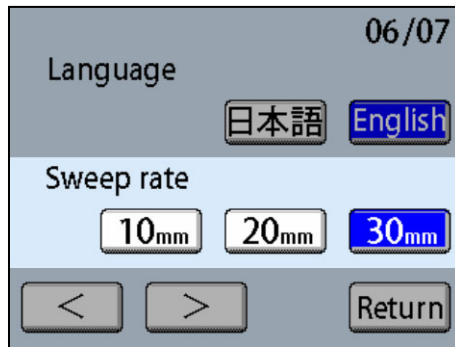

Setting	Details	Initial setting
10mm	Display corresponds to 10mm/min.	
20mm	Display corresponds to 20mm/min.	
30mm	Display corresponds to 30mm/min.	O

Examples of display: There are differences as follows if you measure for 3 minutes in each setting.

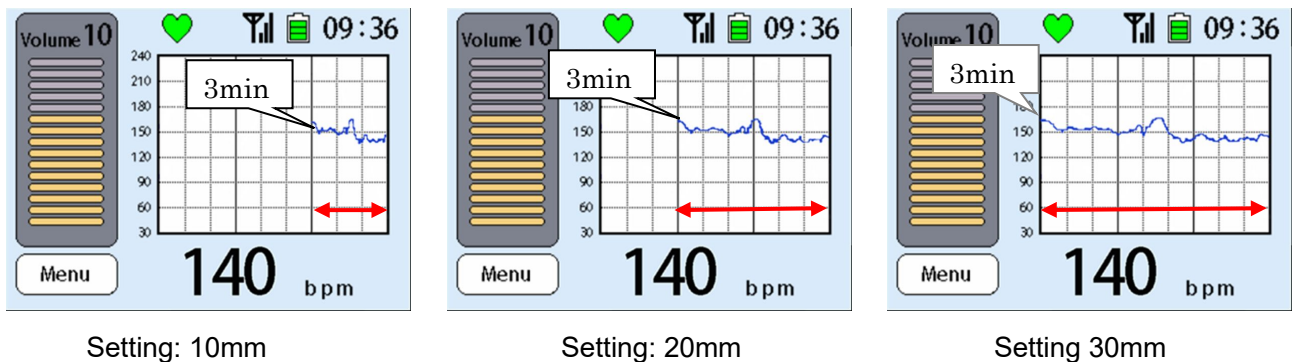

7-10. Wireless Off Timer (Wireless Type Only)

Set the time for activating the standby mode. Switch the power on and standby modes using the operating switch of the wireless probe during standby mode.

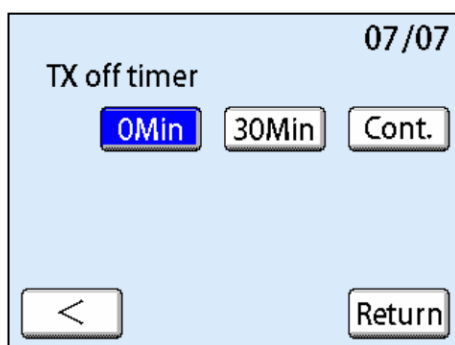

Setting	Details	Initial setting
0 Min	No standby mode.	0
30 Min	Switches to standby mode. The power is turned off by standby for 30 minutes.	
Cont.	Switches to standby mode. Standby continues until the battery level drops to zero. Remains standby condition approximately 24 hours when you use a brand-new battery (alkaline battery). Switch of the operating switch of the main unit after use.	

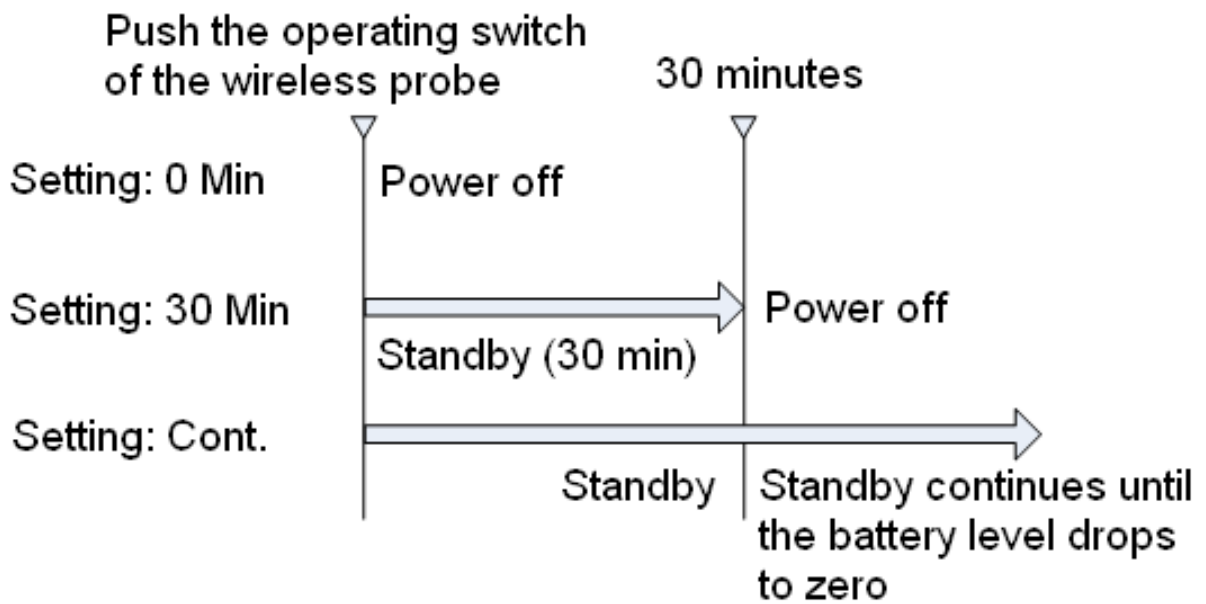

- Behaviors after pushing the operating switch for each setting

8. Cleaning/Inspection/Storage

8-1. Cleaning



WARNING

- This device is not disinfected before shipment. Be sure to disinfect and clean before use.
- Clean and disinfect this device after every use.



CAUTION

- Unplug the power plug before cleaning for safety.
- Conduct an inspection using the checklist in section 8-2 after cleaning.
- Do not insert or remove plug with wet hands. Failure to heed this warning may result in electric shock.

1. Wipe

Main unit:

Wipe periodically with a soft, dry cloth. If it is difficult to remove the stain, clean in the following manner:

- 1) Dip a soft cloth in neutral detergent diluted by warm water (or cold water). Squeeze the cloth thoroughly and wipe a little more firmly.
- 2) Then wipe with the cloth moistened with water that has been squeezed thoroughly.
- 3) Finally, wipe with a soft, dry cloth.

Probe/gel holder:

The probe/gel holder can be removed for washing with water.

- How to remove the holder



1
Support the main unit with one hand.

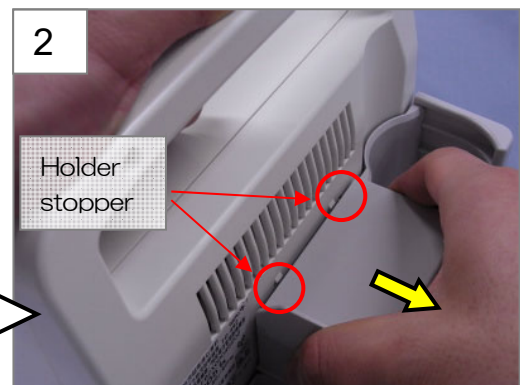

2
Pull to the backside to remove the holder.



3 Pull holder upward from 2) state and remove it from main unit.

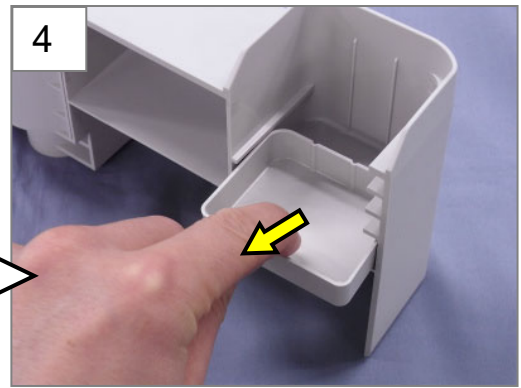

4 Slide the tray to remove.

• How to attach the holder



1 Align the fixed parts of the main unit and holder.

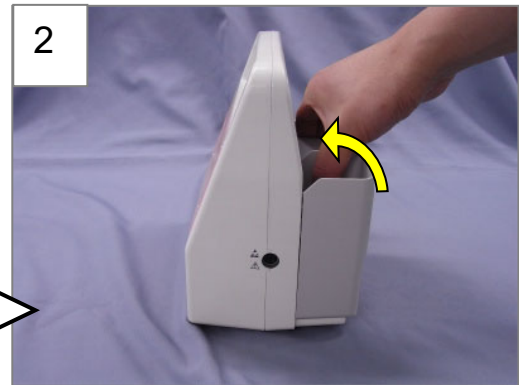

2 Allow the holder to attach to the main unit.



3 Slide downward to attach.

Probe:



CAUTION

- Do not wipe the probe head of the probe with excessive force. This may result in erroneous measurements or a breakdown.

The probe is waterproof and can be washed with water.

- Wired probe

Remove from the main unit and wash with water the connection cord is attached to the wired probe. Check the connection cord to the connector of the wired probe. Pay attention not to expose the connector to liquids. If the unit is exposed to water, wipe the water off thoroughly and dry before use.



Wash with water with the connection cord attached.



Do not wet the connector.



Do not wet the connector.

- Wireless probe



Wash with water while the battery cover closed.

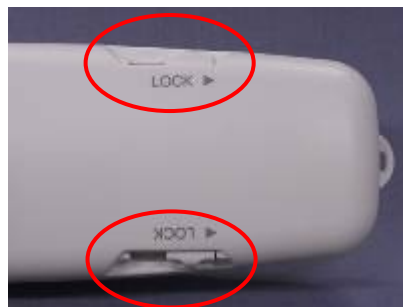

Check the locks.

2. Disinfection

1) Acceptable chemicals:

- Glutaraldehyde (Cidex, Sterihyde, etc.)
- Benzalkonium chloride (Osvan, Diamir, etc.)
- Amphoteric surfactant (Tego 51, Hypal, Anon, etc.)

2) Before disinfection

Wipe the ultrasound gel from the probe carefully with tissues, a soft cloth, or other material.

3) Sterilization

Sensitivity to microorganisms differs by chemical. Follow the efficacy, usage, precautions, and other instructions specified in the package insert for each chemical.

8-2. Inspection



WARNING

- Follow the instructions in this manual. In the event of an abnormality, stop using the device immediately.
- Be sure to check the monitor before use. If you cannot confirm proper operation by inspection, turn off the power and remove the power plug from the outlet. Stop using the device, attach label displaying “Breakdown,” and ask our office or distributor for repairs.
- Do not disassemble or modify this device.



CAUTION

- Do not block the heat vent of this device. Failure to heed this warning may result in a breakdown.
- Do not provide a strong shock such as dropping the probe or bumping the main unit. Failure to heed this caution may result in a breakdown.
- Do not use objects that generate electromagnetic waves such as mobile phone near this device. Failure to heed this caution may result in incorrect measurements.
- Do not use gel other than as specified Ultrasound Gel. Failure to heed this caution may result in signal degradation or damage to the probe.
- Do not use gel other than as specified Ultrasound Gel. Otherwise, it can cause redness and allergies.
- Do not use batteries other than as specified because doing so may cause a breakdown.

1. Inspection

Inspections are required to maintain the functions of this device.

Hospitals or clinics should take responsibility for inspections.

If hospitals or clinics outsource the inspections, they should also assume responsibility for the outsourcing.

Users should conduct the following inspections:

Inspections		Inspection details
Inspection before use	Be sure to conduct before every use of this device.	See "Inspection before use"
Inspection after use	Be sure to conduct after every use of this device	See "Inspection after use"
Inspection in every 6 months	Conduct an inspect of functions in every 6 months	See "inspection every six months"

Failure to confirm proper operation means a breakdown in the monitor. Turn the power off, unplug the power cord, attach a label stating "breakdown; do not use," and ask our office or distributor for repairs.

- Rechargeable battery of the main unit

The performance of the rechargeable battery gradually degrades depending on the conditions of use, environment, and aging. The rechargeable battery must be exchanged after degradation as needed. Ask our office or distributor for an exchange.

2. Checklist of inspections

Conduct inspections in accordance with the inspection details.

• Inspection before use

Serial number:		Inspection date:	Inspected by:
No.	Inspection details		Results
1	No damage to the device.		Pass / Fail
2	The power is turned on by pushing the operating switch.		Pass / Fail
3	No missing display on the LCD screen.		Pass / Fail
4	The power level of the device remains sufficient.		Pass / Fail
5	Correct date and time are displayed.		Pass / Fail
6	The touch panel of the LCD screen reacts correctly.		Pass / Fail
7	When tapping the probe head with the palm of the hand, a sound is emitted from the speaker.		Pass / Fail
8	Sounds with appropriate volume are emitted from the speaker by controlling the volume meter.		Pass / Fail

• Inspection after use

Serial number:		Inspection date:	Inspected by:
No.	Inspection details		Results
1	Remove remaining ultrasound gel and extraneous matter from the device.		Pass / Fail
2	Disinfect the used probe.		Pass / Fail
3	No damage to the device.		Pass / Fail

- Inspection every six months

Serial number:		Inspection date:	Inspected by:
No.	Inspection details		Results
1	No damage to the device.		Pass / Fail
2	No damage to the power cord.		Pass / Fail
3	When you connect the device (the power off) to the power outlet, the rechargeable battery symbol is displayed on the LCD screen.		Pass / Fail
4	When you turn the power on by pushing the operating switch, the LCD screen and the LED of the probe light.		Pass / Fail
5	No missing display on the LCD screen.		Pass / Fail
6	Correct date and time are displayed.		Pass / Fail
7	The touch panel of the LCD screen reacts correctly.		Pass / Fail
8	When tapping the probe head with the palm of the hand, a sound is emitted from the speaker.		Pass / Fail
9	Sounds with appropriate volume are emitted from the speaker by controlling the volume meter.		Pass / Fail
10	When tapping the probe head with the palm of the hand, the heart rate is displayed on the LCD screen.		Pass / Fail
11	No abnormal sound after shaking the device.		Pass / Fail

3. Exchange of the fuse

The device has a fuse to prevent damage from transient overcurrent.

When the power fails to turn on despite the correct connection of the plugs, the fuse may have burned out. Check the fuse by removing the fuse holder and exchange if necessary.

1) Unplug the power cord from the power inlet

2) Pull out the fuse holder using a screwdriver.

The fuse holder cannot be removed from the inlet. Do not pull out too far.



Unplug the power cord and apply a screwdriver to the depressed area.

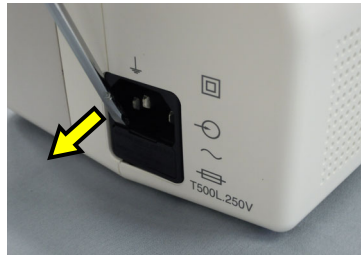

Pull out the fuse holder with the edge of the screwdriver.



Do not pull the fuse holder too far.

3) Remove the burned out fuse

Hold both edges of the fuse with the fingers and push out from upper side of the fuse holder to remove.

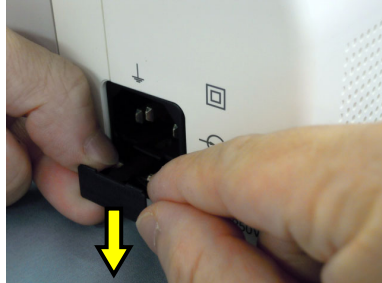

Push out from upper side with a forefinger. Support with the thumb to prevent breaking the removed fuse.

4) Insert a new fuse

Insert a new fuse in the proper position (See the pics below).

Adjust the centers of the fuse and fuse holder.

Use fuse EMG-S250V0.5APBF as specified.

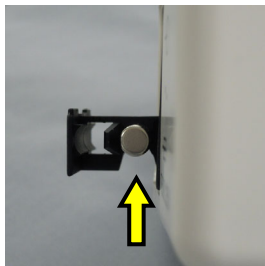

Proper position



Wrong position

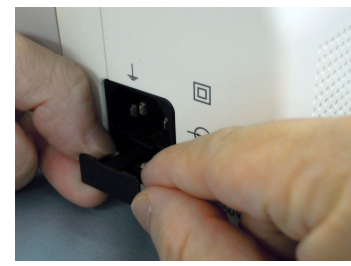

Adjust properly

5) Return the fuse holder

Push the fuse holder into the inlet.

8-3. Storage



CAUTION

- Do not place in the following conditions:
 - Direct sunlight
 - Moisture (95% or more) or dust
 - Heat (at 60°C or more)
 - Coldness (at -10°C or less)
 - Vibrated or unstable places
- Remove the battery of the wireless probe if it will remain unused for a long time.

1. Storage or transport condition:

Ambient temperature: -10°C to +60°C (except of freezing)

Relative humidity: 30 to 95% (no condensation)

Atmospheric pressure: 700-1060hPa

2. If it will remain unused for a long time

- Remove the power cord from the power outlet if it will remain unused for a long time.
- Do not store in locations where the monitor will be exposed to water or moisture.
- Avoid direct sunlight and high temperature and humidity and store in a location where the surface is level without vibration and shock.
- Charge the rechargeable battery every three months because the power level naturally decreases without use. If the monitor will remain unused for three months or longer, remove the rechargeable battery from the device after charging because it may not hold a charge after a long period of disuse.

3. Probe

Remove the battery of the wireless probe to prevent liquid leakage.

9. Troubleshooting



WARNING

- Follow the instructions in this manual. In the event of an abnormality, stop using the device immediately.
- Do not disassemble or modify this device.

This section describes the procedures to address problems for users. If there is no improvement after completing the procedures, ask our office or distributor for repairs since the problem may be caused by a bad internal connection.

- If the connection cord (the side of wired probe) is unplugged:
Connect using the following procedures.

How to connect:

Adjust the O mark on the connector and the position of the strap hole for the L-shape probe (Δ mark for the upright probe) and insert straight without twisting.

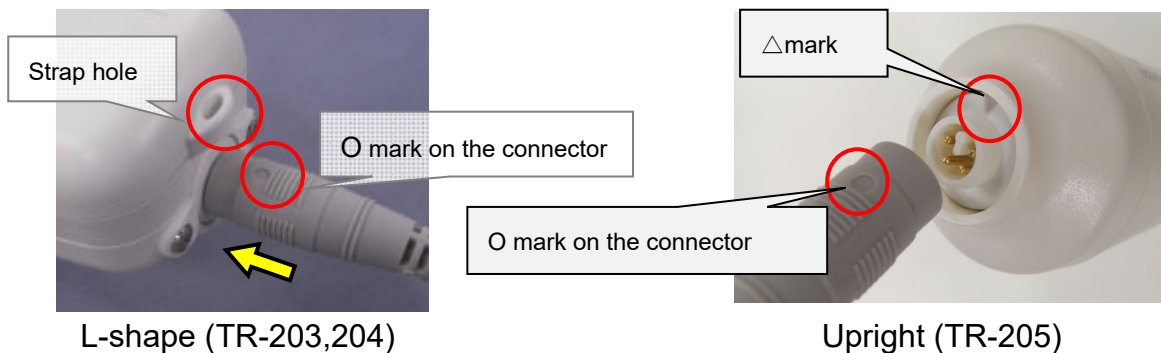

- Reset procedure

If the operation of the main unit is unstable or the unit does not operate, reset the device.

Push the reset switch on the side of the main unit with a paper clip or similar object until there is a discernible click.



9-1. Wired Type

Example of malfunctioning	Possible causes	Solutions
The power of the main unit cannot be turned on.	No AC power	Check the following items: 1. Check the power cord connection. If it is not connected, connect completely. See 5-2 "Charging the main unit, 2. Connection of the power cord." 2. Check for any damage to the power cord. If it is damaged, exchange for a new power cord. 3. Check the fuse to the power inlet. If it is disconnected, exchange for new one. See 8-2 "Inspection, 3. Exchange of the fuse."
	Low battery level	Check the rechargeable battery level of the main unit. If the battery level has decrease, charge it. See 5-2 "Charging the main unit."
The power cannot be turned on by the operating switch of the wired probe (TR-203).	Incomplete connection of the cord	Check the connection cord to the main unit and the wired probe. If it is not connected, connect completely. See 4-2 "Wired Type."
	Abnormality in the connection cord	Check for any damage to the connection cord. If it is damaged, exchange for a new connection cord.
The battery cannot be charged. No battery symbol is displayed on the LCD screen.	No AC power	Check the following items: 1. Check the power cord connection. If it is not connected, connect completely. 2. Check for any damage to the power cord. If it is damaged, exchange for a new power cord. 3. Check the fuse to the power inlet. If it is disconnected, exchange for new one. See 8-2 "Inspection, 3. Exchange of the fuse."
	Breakdown/degradation of the rechargeable battery	Ask our office or distributor to repair.
	Breakdown of the LCD screen	Ask our office or distributor to repair.
The battery level decreases rapidly.	Breakdown/degradation of the rechargeable battery	Ask our office or distributor to repair.
The battery symbol is blinking in red.	Breakdown of the main unit or the rechargeable battery	Ask our office or distributor to repair.
"P" symbol is blinking on the LCD screen and the power is turned off.	Incomplete connection of the cord	Check the connection cord to the main unit and the wired probe. If it is not connected, connect completely. See 4-1 "Wired Type."
	Abnormality in the connection cord	Check for any damage to the connection cord. If it is damaged, exchange for a new connection cord.
The display of the LCD screen is disturbed	Internal error in the main unit.	Reset by pushing the reset switch. See 9 "Troubleshooting, Reset procedure."
	Breakdown of the LCD screen	Ask our office or distributor to repair.

Example of malfunctioning	Possible causes	Solutions
The touch panel shows no reaction.	Internal error in the main unit.	Reset by pushing the reset switch. See 9 "Troubleshooting, Reset procedure."
	Breakdown of the LCD screen	Ask our office or distributor to repair.
The heart rate is not displayed. There are noises in the heartbeat.	Inappropriate position of the probe	Search the appropriate position that provides clear-cut rhythmic sounds.
	Too little gel applied to the probe	Apply the gel evenly.
	Incomplete connection of the cord	Check the connection cord to the body and the wired probe. If it is not connected, connect completely. See 4-2 "Wired Type."
	Abnormality in the connection cord	Check for any damage to the connection cord. If it is damaged, exchange for a new connection cord.
No heartbeat can be heard.	Low volume setting	Check the volume meter of the LCD screen. If it is low, turn up. See 5-4 "Inspection before Use 1. Volume control."
	Incomplete connection of the cord	Check the connection cord to the body and the wired probe. If it is not connected, connect completely. See 4-2 "Wired Type."
	Abnormality in the connection cord	Check for any damage to the connection cord. If it is damaged, exchange for a new connection cord.
The power is suddenly turned off.	The function of no signal power down or automatic power down worked.	The no signal condition for 2 minutes or at 10 minutes after the power on leads to power off. Change the settings as needed. See 7-1 "No Signal Power Off" and 7-2 "Automatic Power Off."
The power cannot be turned off.	Internal error in the device	Reset by pushing the reset switch. See 9 "Troubleshooting, Reset procedure."
Abnormal sounds are emitted from the speaker.		

9-2. Wireless Type

Example of malfunctioning	Possible causes	Solutions
Pairing cannot be conducted.	Too far between the wireless probe and the main unit	Allow the body and the wireless probe to move closer to conduct pairing.
	Abnormal beginning of pairing	Check the LED of the wireless probe and the symbol for radio wave strength. If symbols are not blinking start from the first procedure again. See 4-3 "Wireless Type, 2. Pairing."
	Other wireless devices used close	Stop other wireless device or keep it far from this device to conduct pairing.
The power of the main unit cannot be turned on.	No AC power	Check the following items: 1. Check the power cord. If it is not connected, connect completely. See 5-2 "Charging the Main Unit, 1. Connection of the power cord." 2. Check for any damage to the power cord. If it is damaged, exchange for a new power cord. 3. Check the fuse to the power inlet. If it is disconnected, exchange for new one. See 8-2 "Inspection, 3. Exchange of the fuse."
	Low battery level	Check the rechargeable battery level of the main unit. If the battery level has decreased, charge it. See 5-2 "Charging the Main Unit."
The power of the wireless probe cannot be turned on.	Low battery level	Change the battery of the wireless probe. See 4-3 "Wireless Type 1. How to insert the battery."
The battery cannot be charged or start to be charged. No battery symbol is displayed on the LCD screen.	No AC power	Check the following items: 1. Check the power cord. If it is not connected, connect completely. See 5-2 "Charging the Main Unit, 1. Connection of the power cord." 2. Check for any damage to the power cord. If it is damaged, exchange for a new power cord. 3. Check the fuse to the power inlet. If it is disconnected, exchange for new one. See 8-2 "Inspection, 3. Exchange of the fuse."
	Breakdown/degradation of the rechargeable battery	Ask our office or distributor to repair.
	Breakdown of the LCD screen	Ask our office or distributor to repair.
The battery level decreases rapidly despite charging with no problems.	Breakdown/degradation of the rechargeable battery	Ask our office or distributor to repair.
The battery symbol is blinking in red.	Breakdown of the main unit or the rechargeable battery	Ask our office or distributor to repair.
"P" symbol is blinking on the LCD screen and the power is turned off.	Too far between the wireless probe and the main unit.	Allow the main unit and the wireless probe to move closer.
	Other wireless device is too close	Stop other wireless device or keep it far from this device to conduct pairing.
	Low battery level	Change the battery of the wireless prob. See 4-3 "Wireless Type 1. How to insert the battery."

Example of malfunctioning	Possible causes	Solutions
The main unit and the wireless probe cannot connect wirelessly.	Too far between the wireless probe and the main unit	Allow the main unit and the wireless probe to move closer.
	Wrong pair of wireless probe and the main unit * When using multiple pairs	Turn the power on individually to check the pair.
	Wireless communication error	If you turned on the power immediately after power off, it may be difficult to connect wirelessly. Turn on the power 5 seconds or more after power off.
The display of the LCD screen is disturbed.	Internal error	Reset by pushing the reset switch. See 9 "Troubleshooting, Reset procedure."
	Breakdown of the LCD screen	Ask our office or distributor to repair.
The touch panel shows no reaction.	Internal error	Reset by pushing the reset switch. See 9 "Troubleshooting, Reset procedure."
	Breakdown of the LCD screen	Ask our office or distributor to repair.
The heart rate is not stably displayed. There are noises in the heartbeat.	Inappropriate position of the probe	Search the appropriate position that provides clear-cut rhythmic sounds.
	Too little gel applied to the probe	Apply the gel evenly.
	Too far between the wireless probe and the main unit	Allow the body and the wireless probe to move closer.
	Other wireless devices used close	Stop other wireless device or keep it far from this device to conduct pairing.
No heartbeat can be heard.	Low volume setting	Check the volume meter of the LCD screen. If it is lower, turn up.
	Too far between the wireless probe and the main unit	Allow the main unit and the wireless probe to move closer.
	Other wireless devices used close	Stop other wireless device or keep it far from this device to conduct pairing.
The power is suddenly turned off.	The function of no signal power off or automatic power off was worked	The no signal condition for 2 minutes or at 10 minutes after the power on leads to power off. Change the settings as needed. See 7-1 "No Signal Power Off" and 7-2 "Automatic power off."
The power of the wireless probe cannot be turned off.	Internal error of the probe	Reinsert the battery of the wireless probe. See 4-3 "Wireless Type 1. How to set the battery."
The power cannot be turned off.	Internal error of the device	Reset by pushing the reset switch. See 9 "Troubleshooting, Reset procedure."
Abnormal sounds are emitted from the speaker.		

10. Specifications

10-1. Product Specifications

Main unit

Power-supply voltage	AC 100 – 240 V
Power-supply frequency	50/60 Hz
Power consumption	30 VA
Rated voltage (internal power supply)	7.2 V
Power consumption (internal power source)	15 VA
Continuous operating time (internal power source)	160 min
Charging time	70 min
Dimensions: width × height × depth	200 × 195 × 125 mm
Weight	1.5 kg
Outer protection level against ingress of water	IPx0
Display function	LCD screen: Displays operating conditions, settings, battery level and abnormal conditions
Operating function	Settings and maintenance
External output	Earphone jack
Wireless communication	Type: 2.4GHz upgrade low power data communication system Type of radio wave,, frequency and aerial power: F1D, 2441 MHz, 0.0000121-0.0000475 W/MHz G1D, 2441 MHz, 0.0000052-0.0000206 W/MHz

Wired probe TR-203(L-shape)

Protection type to electric shock	AC power	Class II device
	Battery	Internally-powered device
Classification of attached area by protection level	Attached part type B	
Dimensions: width × height × depth	46 × 130 × 50 mm	
Weight	0.1 kg	
Outer protection level against ingress of water	IPx7	
Materials of parts which contact to human body	PC, ABS/PC, Elastomer	
Applied part (Maximum temperature)	Probe head (43°C)	
Display function	LED indicator: indicates operation status	

Wired probe TR-205(Upright)

Protection type to electric shock	AC power	Class II device
	Battery	N/A
Classification of attached area by protection level	Attached part type B	
Dimensions: width × height × depth	35 × 122 mm	
Weight	0.05 kg	
Outer protection level against ingress of water	IPx7	
Materials of parts which contact to human body	ABS/PC	
Applied part (Maximum temperature)	Probe head (43°C)	

Wireless probe TR-204

Rated voltage	1.2 V
Power source	AA battery
Power consumption	0.57 VA
Continuous operating time	180 min (Alkaline battery/new/at 28°C*) 250 min (Nickel metal-hydride battery/new/full charge)
Protection type to electric shock	Internally-powered device
Classification of attached area by protection level	Attached part type B
Dimensions: width × height × depth	46 × 130 × 50 mm
Weight	0.1 kg
Outer protection level against ingress of water	IPx7
Materials of parts which contact to human body	PC, ABS/PC, Elastomer
Applied part (Maximum temperature)	Probe head (43°C)
Display function	LED indicator: indicates operation status, remaining battery, abnormal conditions
Operating function	Settings
Wireless communication	Type: 2.4GHz upgrade low power data communication system Type of radio wave, frequency and aerial power: F1D, 2441 MHz, 0.0000121-0.0000475 W/MHz G1D, 2441 MHz, 0.0000052-0.0000206 W/MHz

Measurement specifications (fetal heart rate by Doppler ultrasound)

Ultrasound drive method	Continuous wave
Oscillating frequency	2.5 MHz +/-10%
Ultrasound output	10mW/cm ² or less
Peak sound pressure in peak time of space	21.2kPa
Effective region of ultrasonic transducer	119 mm ²
Heart rate measuring range	50-240bpm
Accuracy of heart rate measurement	Within ± 3bpm

The thermal index and mechanical index are not more than 1.0 in all setting conditions.

Cables

Type	Item code	Max. Length
Power cord		2.9 m
Curl cord	YC0104	2.5 m
Earphone cord		1.3 m

Use of cables other than the specified above may cause an increase in emissions or reduce the resistance to interference of this device.

10-2. Accessories

Names	Item code	Quantity	Cable length	Remarks
Wired probe TR-203	JA1693	1	-	Wired type FD-491 only
Curl cord for TR-203	YC0104	1	2.5 m	Wired type FD-491 only
Wireless probe TR-204	JA1706	1	-	Wireless type FD-492 only
Wired probe TR-205	JA1983	1	-	Wired type FD-491 only
Curl cord for TR-205	YC0104	1	2.5 m	Wired type FD-491 only
Ultrasound gel		1	-	
Fuse	SA0058	2	-	EGM-S250V0.5APBF One in the inlet, one spare
Power cord		1	2.9 m	
Operation manual	GZ1269	1	-	
Package insert		1	-	
Alkaline battery (for performance check)	SG0028	1	-	Wireless type FD-492 only
Mini-DIN connector cover	SD0731	1	-	When using a wireless probe TR-204

10-3. Usable service life/Warranty/Disposal

Usable service life

The usable service life of this device is 6 years after shipment. Service life is based on the self-certification (our data). Some components may degrade with age within the usable service life. Regularly exchange the components to maintain the performance of this device during the usable service life. Repair or overhaul depending on the results of inspections as needed.

Warranty

We will repair the device free of cost within the warranty period according to the provisions of the warranty. In the event of a breakdown after the warranty period, we will repair only devices that can be returned to normal operation, and you must bear the cost. The repair parts necessary for repair will be stored for 6 years after the device is sold.

Disposal

This device is categorized as an industrial waste. Contact the local government about disposal.

10-4. Service parts

The usable service life of this device is 6 years. However, the following components are supplied for maintenance since they have a shorter usable service life than that of the device. Repair parts necessary for repair will be stored for 6 years after the device is sold. Exchange timing depends on the frequency and environment of usage of the device. Exchange the components if you find it necessary during inspections. Ask any questions to our office or distributor.

Names of major components	Usable service life	Reason of usable service life
Rechargeable battery for the main unit (nickel metal-hydride)	2 years	Aged degradation
Probe	5 years	Degradation of ceramic adhesion Degradation of movable connection of cord
Curl cord	3-4 years	Degradation of movable connection and coating
Power cord	3-4 years	Consumable, deterioration of coating of cord

Notification to Users

We must provide information about efficacy and safety, and other necessary information for proper use of the device to all users. And we (the manufacturer) and competent authority must be notified of any serious incident information related to this device. Please take a few minutes and inform us about the following information if any negative problem was caused by use of the device.

(Inform) Medexa Diagnostisk service AB
11b Krossverksgatan Limhamn Sweden
Tel: +46040160020 E-mail: info@medexa.se
URL: <https://www.medexa.se/>

● Address

● Name of facility

● Person in charge

Device name: Doppler Fetus Detector FD-490 (FD-491, FD-492)

Serial number:

Problem

(This page is blank)

(This page is blank)

(This page is blank)



TOITU CO., LTD.

1-5-10, Ebisu-Nishi, Shibuya-Ku,
Tokyo 150-0021, Japan

Tel: +81-3-3463-6381

Fax: +81-3-3463-6380

E-mail: international@toitu.co.jp

URL: <http://en.toitu.co.jp/>